

D
AN
IELS

Master of Architecture

Master of Landscape Architecture

Master of Urban Design

Master of Visual Studies

Master of Forestry

Doctor of Philosophy in Architecture, Landscape, and Design

Doctor of Philosophy in Forestry

New
Graduate
Student
Handbook
2020-2021

OF
T
U

Page 3	Welcome
Page 4	Office of the Registrar and Student Services
Page 6	Getting Started
Page 8	Supporting Your Success at Daniels
Page 10	Student Facilities
Page 13	Life in the Daniels Community
Page 18	Programs and Registration
Page 24	Fees and Financial Support
Page 34	Master of Architecture
Page 38	Master of Landscape Architecture
Page 42	Master of Urban Design
Page 44	Master of Visual Studies
Page 52	Master of Forest Conservation
Page 54	Master of Science in Forestry
Page 56	Doctor of Philosophy in Architecture, Landscape, and Design
Page 58	Doctor of Philosophy in Forestry
Page 60	Collaborative Programs and Research Centres
Page 64	Important Dates 2020-2021
Page 68	Select UofT Services

Welcome

Welcome and congratulations on your decision to join us at the John H. Daniels Faculty of Architecture, Landscape, and Design (Daniels) at the University of Toronto. We are excited to have you join our community! The University of Toronto is a large, vibrant institution spanning three campuses and includes over 19,000 graduate students. It is a world leader in learning and research innovation with many opportunities and experiences for students.

As part of the Daniels graduate student community, you are entering an academic community engaged directly with professionals in the field, alumni of our programs, and the city of Toronto as a platform for exploring global issues in the context of design as a discipline. Daniels is a place where you will study and collaborate with leaders in the fields of architecture, landscape, urbanism, and art while accessing state of the art facilities and finding support and engagement with your peers, faculty members, and staff as you immerse yourself in your graduate experience.

The Office of the Registrar and Student Services is involved in and provides support throughout your entire academic experience, from admissions through to graduation. We are your first stop for information on Faculty and School of Graduate Studies (SGS) policies and procedures as you navigate your graduate experience. While it is your ultimate responsibility as a student to be aware of the rules and regulations of the Faculty and SGS, we are available to assist you and provide support and guidance. You will find the official guide to the rules and regulations (including, but not limited to, degree requirements, programs, and courses) for Daniels graduate programs in the School of Graduate Studies Calendar and this handbook.

We hope that you will find this handbook useful. It has been created to assist you in navigating the Faculty and the University as a whole. If you have any questions regarding academic, financial, or personal concerns, we encourage you to reach out to the Office of the Registrar and Student Services so that we can assist you. Have a fabulous year and we look forward to seeing you in September.

Andrea McGee
Registrar and Assistant Dean, Students
registrar@daniels.utoronto.ca. 416-978-2572

Information for Family Members and Partners about Student Privacy: We recognize that there are many instances where family members and partners will play an important role in a student's life by providing advice and encouragement. While the natural inclination may be to get involved to try and solve a problem for the student, as a matter of University policy we cannot discuss any aspect concerning a student with anyone. Please encourage contacting the Office of the Registrar and Student Services directly when questions, concerns, or requests arise. If a student wishes us to share any information, written consent from the student is required. Please visit the University of Toronto's website for families of students at:
<http://www.studentlife.utoronto.ca/parents-and-family-0>

Office of the Registrar and Student Services

The Office of the Registrar and Student Services is committed to facilitating the highest level of excellence in graduate education administration. In addition to performing registrarial functions jointly with the School of Graduate Studies, this office provides academic, financial, and general advising, and is available to assist students when experiencing any difficulties that might have an impact on academic performance, such as illness, a family emergency, or financial problems. Areas with which the Office of the Registrar and Student Services provide assistance include, but are not limited to:

- Academic and general advising and guidance
- Degree requirements
- Elective course selection
- Fee payment or fee deferral
- Financial counseling/bursary applications
- Withdrawal from courses/the University
- Academic appeals
- Examination/Review timetable
- General information on international opportunities
- Faculty awards and scholarships

A student's experience is about more than the academic experience. The University and Daniels Faculty offer an array of leadership, mentorship, and discipline-specific opportunities designed to augment academic experience and encourage in-depth research at Daniels and the University at large.

The Office of the Registrar and Student Services is available to help. Visit the website, stop by the office, or call. Appointments can be made in person or by phone.

Location: 1 Spadina Crescent, Toronto, ON M5S 2J5
Tel: 416-946-3897
Email: registrar@daniels.utoronto.ca
Web: <https://www.daniels.utoronto.ca/info/current-students/graduate>

Office Hours: Please visit the Daniels website for operational hours.

School of Graduate Studies

The University of Toronto is the largest graduate school in Canada with over 19,000 graduate students from all over the world. The wide range of areas of study and interdisciplinary programs ensure that students can tailor their graduate experience. Sharing responsibility for graduate studies with graduate units and divisions such as the Daniels Faculty, and operating through a system of collegiate governance, consultation, and decanal leadership, SGS defines and administers University-wide regulations for graduate education.

The School of Graduate Studies publishes the official academic calendar. This academic calendar is the official document which outlines degree and program requirements, and the rules and regulations which govern the graduate experience at U of T. To view the current academic sessions SGS Calendar, visit:

<https://sgs.calendar.utoronto.ca/>.

Areas with which the School of Graduate Studies provides assistance include, but are not limited to:

- Financial counseling/bursary applications
- Change of name
- Change of legal status in Canada
- Confirmation of enrolment letters
- University-Wide and Government Awards and Scholarships

Location: 63 St. George Street, Toronto, ON M5S2Z9
Tel: 416-978-6614
Email: graduate.information@utoronto.ca (general inquiries)
Web: <http://www.sgs.utoronto.ca/>
Office Hours: Please visit the SGS website for operational hours.



Getting Started

ACORN

ACORN stands for Accessible Campus Online Resource Network. ACORN is where students enrol in elective courses, check fees and finances and perform other records and registration tasks such as updating their address and contact information and ordering official academic transcripts. The purpose of ACORN is to provide a more convenient, personalized and guided experience for students using U of T's online services. Take the time to review the help topics to better understand ACORN.

TCard and Official Communication

All students must have an official University of Toronto e-mail address. Very little information is sent by post. If you do not obtain an **@mail.utoronto.ca** e-mail address and check it regularly, you will miss a large amount of important information. You cannot opt out of e-mail communication sent from the Office of the Registrar and Student Services since this is the official communication mechanism for academic matters. The Office of the Registrar and Student Services will not send e-mail communication to an e-mail address other than your @mail.utoronto.ca address once you have obtained your TCard. It is very important for you to update the student online service (ACORN website: www.acorn.utoronto.ca) with your official University of Toronto e-mail address as soon as you receive it. You will obtain your e-mail address when you get your TCard.

Please remember to also update your mailing address and phone number on ACORN. If you move into residence or off-campus housing in September, you should update your contact information at that time. Make sure this information is accurate throughout your time at the University, since you will miss important information if we are not able to contact you.

Your TCard is your official University of Toronto student card. To pick up your TCard, you must bring your offer of admission and proof of citizenship to the TCard office on the first floor of the Koffler Student Service Centre at the intersection of St. George and College Streets.

TCard Office: Koffler Student Service Centre, Room 102, 214 College St.
Website: www.tcard.utoronto.ca
Summer Hours: Monday, Wednesday, Thursday, and Friday: 9:00 am to 5:00 pm
Tuesday: 9:00 am to 6:00 pm

FOB Keys

You will be issued a FOB key that will grant you access to all Daniels Faculty buildings. 1 Spadina, North Borden and South Borden. Prior to picking up your FOB key, you will be required to pay a \$100 key deposit, refundable upon request at degree completion. The replacement cost for a lost FOB is \$25; this replacement cost is non-refundable.

Information about how and when to pay your deposit and when and where to pick up your FOB will be emailed to students in August.

Academic Calendar and Timetable

The School of Graduate Studies Calendar (SGS) is the official guide to the rules and regulations pertaining to all graduate programs, including but not limited to, a listing of courses offered, degree requirements, and program details. This handbook provides further details specific to Daniels Faculty graduate programs including expectations, the cohort schedule of courses, and course enrolment information. All newly admitted and current students are strongly encouraged to review the SGS Calendar along with the Academic Timetable.

<https://sgs.calendar.utoronto.ca/sites/public/sgs/files/2019-20-SGS-Calendar.PDF>

<https://www.daniels.utoronto.ca/info/current-students/graduate>

<https://forestry.utoronto.ca/current-student-resources/>

Daniels Computer Account

All students require a Daniels Computer account to access the computing resources at the Daniels Faculty. Accounts are created automatically by the IT Office. New students will receive an email to their UTMail+ inviting them to activate their computer account by the end of August. In order to complete the activation process, students must log in and change their password. More details on activating a Daniels Computer account can be found here: [Accounts Activation](#). Contact it@daniels.utoronto or visit their office in DA177 at One Spadina.

Getting Help

Information Technology Services

Location: 1 Spadina Crescent, Room 177 Toronto, ON M5S 2J5

Email: it@daniels.utoronto.ca

Web: <https://www.daniels.utoronto.ca/info/current-students/undergraduate/it-support/your-student-account>

Office Hours: Monday – Friday 9:30am – 5:00pm

Summer Hours: Monday – Friday 9:30am – 4:30pm

Software

The University, Faculty, and partners of the University provide a variety of software for students to download and install on their computers. More information can be found on the website:

<https://www.daniels.utoronto.ca/info/current-students/undergraduate/it-support/your-laptop-software>

Supporting Your Success at Daniels

Student Advising

The Daniels Faculty is committed to helping all students reach their highest learning potential and recognizes that not everyone learns the same way and many students may need additional support or direction. Students who find themselves in academic or personal distress, or believe they could use assistance in navigating their graduate career, are encouraged to book an appointment with the Office of the Registrar and Student Services to familiarize themselves with the supports and resources available within Daniels and the University community. To book an appointment, please call the Office of the Registrar and Student Services at 416-946-3897 or email us at registrar@daniels.utoronto.ca.

Daniels Writing Centre

The Writing Centre at the John H. Daniels Faculty of Architecture, Landscape, and Design is a resource for all Daniels students seeking assistance with academic writing and related academic skills. The Writing Centre offers academic support for integrating written, spoken, and visual communication. Our primary service is consultation-based writing instruction (individual and group) that involves a wide range of approaches including:

- Assessing general writing strengths and weaknesses
- Mechanics, usage, grammar, and style
- Pre-writing and brainstorming
- Citing and integrating sources
- Developing a thesis
- Rhetoric and argumentation
- Formal analysis and writing in the disciplines
- Outlines, paragraphs, topic sentences
- Revising and editing skills

The Writing Centre also works closely with the Daniels Faculty to support teaching by researching and producing resources as well as collaborating with instructors to deliver in-class workshops. We offer individual consultations on designing more effective assignments and evaluation methods that help align academic expectations with student learning.

On Location Wellness Counselor

A registered Social Worker and/or Psychologist is available to provide counseling services specifically to Daniels students throughout the term. This is in addition to the support that can be found at the Central Health & Wellness offices. Please review the information on the Daniels website closer to September to find out when our Counselor will be available to see Daniels students.

To book an appointment, please call 416-978-8030 ext.5 and identify yourself as a Daniels student.

On Location Career Educator

A Career Educator is available to meet with Daniels students to assist with job search strategies, exploring career options, and further education in the Fall and Winter semesters. During the summer term please book an appointment by calling (416) 978-8000, sending an email to careercentre@mail.careers.utoronto.ca, or utilizing the online chat, available at <http://www.studentlife.utoronto.ca/cc/chat>

A wide variety of workshops and programs are offered at Career Exploration & Education (214 College St.) to support your career and further education decision-making and journey. Further information about these offerings is available on Career and Co-Curricular Learning Networking (CLNx / <https://clnx.utoronto.ca>), via Events and Workshops Calendar (St. George Career Centre), as well as under Programs. Contact Career Exploration and Education at (416) 978-8000 or careercentre@mail.careers.utoronto.ca.

Learning Skills Strategist

Learning Strategists at the Academic Success Centre are available to all graduate and undergraduate students to support the development of their study skills and academic strategies. Whether you are an exceptional student looking to refine your skillset or a struggling student unsure of the next steps to improve your learning process; meeting with a Learning Strategist is a great way to reflect on your experience and develop new strategies in a supporting environment.

Topics include (but are not limited to):

- Learning as a Process
- Motivation & Goal Setting
- Time Management & Procrastination
- Stress Management & Anxiety Reduction
- Study Focus
- Critical Reading & Note-Taking
- Presentations & Public Speaking
- Test, Exam, Review and Critique Preparation

Learning Strategists are available through the Academic Success Centre <http://www.studentlife.utoronto.ca/asc/learning-strategies>

Student Facilities

Studio Space

Incoming MArch, MLA, MUD and MVS Studio students will be assigned studio space within shared studio rooms. At this time due to COVID-19, students will not be assigned any studio space until further notice. MVS students will work with their director regarding space. When we are able to return and assign space, they are assigned by year of study and studio group and require a FOB key to access the studio spaces. Each MArch, MLA, and MUD studio desk comes with a lockable storage cabinet. Students need to provide their own lock. The Daniels Faculty is not responsible for any damaged or stolen property.

Do not prop studio doors open or allow strangers to enter into the studio space when opening the door with a FOB. If you are having issues accessing the studio spaces with your FOB, update your key at one of the hotspot readers throughout the building, or visit the Office of the Registrar and Student Services. Anyone in the studio space or building who should not be there (particularly after hours) or any vandalism or stolen items should be reported to Campus Police by calling 416-978-2222, and to the Office of the Registrar and Student Services in person, by calling 416-946-3897 during operational hours, or emailing registrar@daniels.utoronto.ca immediately.

Digital Fabrication Lab / Workshop

The model workshop provides a safe, well-equipped environment in which students and faculty can explore three-dimensional construction using a wide variety of materials.

When students require the use of specific and more advance tools they should individually visit the workshop to obtain an initial training session. Contact the Workshop by email to arrange a time for the initial training session. The session is 3 hours long. Trainees must also complete a self-directed shop time to build a small project. This project must be done within a week of the initial training session. The shop will provide the material and the final project is the student's to keep.

The Digital Fabrication Laboratory is equipped with facilities for the production and manufacturing of advanced prototypes. The lab includes a variety of computer numerically controlled technologies, including a large 3-axis router, a fused deposition modeling rapid-prototyping system, a ZCorp color 3D printer, Microscribe Digitizer, Next Engine 3D laser scanner, several laser cutters and a suite of workstations. The laboratory is centrally linked to a wireless network server that enables students and faculty to work fluidly together throughout the environment of the school.

Location: 1 Spadina Crescent, Room 060 Toronto, ON M5S 2J5
Tel: 416-978-3117
Email: facilities@daniels.utoronto.ca
Web: <https://www.daniels.utoronto.ca/info/current-students/resources/model-workshop>

Printing and Plotting

There is a charge for all printing or plotting (large format printing) at the Daniels Faculty. Colour and black & white laser printing can be done directly from a student's own computer, or through a lab computer. Plotting is done through the web with the IT service WebPlot, or done directly by using an OCE printing computer station in the printing area. For print account balances, recent transactions, or any error messages, students may check their Daniels Account.

Information about how to print or plot can be found on the website: <https://www.daniels.utoronto.ca/info/current-students/undergraduate/it-support/printing-plotting>

Eberhard Zeidler Library

With over 35,000 volumes, with a focus on contemporary architecture, landscape architecture, and urban design (20th & 21st centuries) the Eberhard Zeidler Library is part of the extensive U of T library system that serves Daniels students. Further details on the Eberhard Zeidler Library including hours, available services (including loans, reference), tutorials, research guides, etc. are available online.

Relevant related collections are available at Robarts, Thomas Fisher Rare Books, Noranda Earth Sciences, Engineering and Gerstein libraries. In addition, the Department of Art Library comprises over 40,000 exhibition catalogues, dealer catalogues and permanent holdings catalogues from Europe and North America.

Explore the University of Toronto Libraries resources (print and electronic) at <https://onesearch.library.utoronto.ca> – your starting point!

Location: 1 Spadina Crescent, Room 145, Toronto, ON M5S 2J5
Tel: 416-978-2649
Email: library@daniels.utoronto.ca
Web: www.daniels.utoronto.ca/resources/library/eberhard-zeidler-library

Hours of Operation: Vary throughout the term.

Please check online for the most up-to-date hours:

<https://www.daniels.utoronto.ca/resources/library/hours-contact>

Labs at Forestry

Centre for Biocomposites and Biomaterials Processing

CBBP is working on the development of next generation energy efficient lightweight performance nanomaterials for industrial applications including aerospace, automotive, bio-medical and electronics.

Thomas Research Lab

Research in the Thomas lab addresses how trees and forests respond to human impacts, and how forest management can enhance ecosystem “services” (things people want from forests), ranging from biodiversity to carbon sequestration and climate mitigation. Recent research has taken a turn to the biochar (or charcoal used as soil amendment). Currently exploring many aspects and applications of biochar, including its use for remediation of contaminated substrates such as mine tailings, its use as a soil amendment in N-saturated forest ecosystems, and biochar from the perspective of emulating natural fire disturbance.

Fire Management Systems Laboratory

The staff and students associated with the Fire Management Systems Laboratory study the impact of fire in Boreal forest ecosystems and use operational research methods and information technology to develop decision support systems for fire and forest managers.

Wood Composite Lab

Specializes in forest-based biomaterials science and composites, bio-based adhesives and adhesion, digital printing, and surface sciences of paper. Developing novel environmentally-friendly green bio-based composites, producing green chemicals using renewable forestry biomass as feedstock, and engineering the next generation high valued paper based products.

Thermal analysis and characterization where the properties of materials change with temperature or time.

Common instruments to manufacture heat activated resinated wood fiber composite and measure mechanical properties.

Provide industrial and wood pressure treatment process in an effort to simulate various wood treatment processes to improve efficacy.

Research focus on treatment efficacy, protection against biological decay, UV resistance and environmental impact of biocides.

Haliburton Forest

Mobile canopy lift for canopy access and experimentation on the ecophysiology and structure of canopy trees.

Canopy meteorological tower with meteorological instrumentation and eddy flux systems for energy, CO₂, and methane flux.

Life in the Daniels Community

There are hundreds of opportunities at the University of Toronto for students to become involved on campus and within the Daniels Faculty. Becoming engaged in the student life within the Faculty is a valuable and rewarding experience and can help you develop or refine skills and competencies that are highly transferable to the workplace.

Daniels offers many events for students' engagement including student lead social events, public lectures, exhibitions, professional networking opportunities, and the Daniels Fora. These Faculty initiatives present engaging opportunities which bring together different perspectives from students, alumni, and professionals, and the broader public in order to raise the level of debate, build relationships, and stimulate discussion among students, academics, institutions, and the general public. Students are strongly encouraged to participate and attend in the many Faculty events throughout the year.

Daniels Spaces on Campus

Daniels is currently occupying four buildings on campus:

1. Daniels Faculty at 1 Spadina Crescent: The new home of the Daniels Faculty, located on the Western edge of campus in the revitalized heritage building.
2. North and South Borden Buildings at 563 and 487 Spadina Avenue: Undergraduate and graduate Visual Studies student spaces, classrooms, and faculty offices can be found at this location.
3. 33 Willcocks (Forestry, Earth Science building): Spaces for undergraduate and graduate Forestry students, classrooms, and labs can be found here

Daniels Communications

Throughout the year, the Daniels Communications team will be working hard to keep everyone up to date on faculty, student, and alumni news, notices, and events. In addition to the information students will receive via e-mail in the Daniels Newsletter, all public news and notices will be regularly posted on the Daniels website. Students may contact communications@daniels.utoronto.ca to ask to be removed from the e-mail list. Students cannot, however, opt out of e-mail communication sent from the Office of the Registrar and Student Services since this is the official communication mechanism for academic matters.

Follow [@UofTDaniels](#) on Twitter, visit the Daniels Faculty page on Instagram, like the Daniels Faculty page on Facebook, watch the Daniels Faculty YouTube channel, and follow the Daniels Faculty on Pinterest.

Do you have a newsworthy event that you would like to share? Perhaps you have recently won a competition, had your work featured in the media, or participated in an exhibition. Send your news to

communications@daniels.utoronto.ca so that the Communications team can post it on our website and in our newsletter. Please provide relevant links and a photo to accompany the story.

The Daniels Faculty wishes to showcase the work and accomplishments of its students. To this end, the Daniels Faculty takes photographs of students and of their work during public events, lectures, and reviews. If you do not wish to have your photograph taken, please contact the Communications team at:

communications@daniels.utoronto.ca

FGSA

The Forestry Graduate Students' Association (FGSA) was established in 1969 in response to a growing number of graduate students. All graduate students at the University of Toronto registered in the Forestry Department of the School of Graduate Studies are members of the FGSA.

The FGSA's executive members are committed to ensuring that all forestry graduate students have a positive and enriching academic experience. We do this by hosting social and networking events, continuously collecting feedback from graduate students, and creating a platform for students to raise any and all questions and concerns they may have regarding their graduate experience.

FGSA Website - <https://uoftfgsa.weebly.com/>

GALDSU

The Graduate Architecture, Landscape, and Design Student Union (GALDSU) is a democratically-elected course union representing, individually and collectively, all students in the four graduate programmes at the John H. Daniels Faculty of Architecture, Landscape, and Design: Architecture, Landscape Architecture, Urban Design and Visual Studies. The purpose of GALDSU is to ensure the protection of graduate students' rights and advocate for their needs.

In addition, GALDSU provides diverse athletic, cultural and social opportunities to its members by initiating, sponsoring, co-ordinating, and promoting a wide range of initiatives.

GALDSU website: <http://www.galdsu.ca/>

GSU

The Graduate Students' Union at the University of Toronto represents over 15,000 students studying in over 85 departments. For many years this union has advocated for increased student representation, funding, and provided services such as health insurance, confidential advice, and a voice for the graduate student body on the various committees of the University. This section describes how the Union is organized, what we do, and how you can become involved. The best way for your Union to represent you, is to have your voice heard. GSU website: <https://www.utgsu.ca>

For information about Health and Dental Plans visit <https://www.utgsu.ca/>

G2G Peer Advisors

The G2G (grad-to-grad) Peer Advisors are masters and doctoral students trained in conflict resolution coaching. Grad students can talk confidentially with a G2G about any academic issue. A G2G will not "take sides", advocate or intervene on a student's behalf; a G2G will help students to explore what their options are (pros and cons), what policies apply and what resources are available, and can help prepare for a difficult conversation.

G2G website: <http://gradcrc.utoronto.ca/g2g/>

Gradlife

Gradlife is an excellent resource supported by the School of Graduate Studies where students can connect to specialized workshops, social events, online resources and publications to support their graduate student life at U of T.

For more information visit <http://www.sgs.utoronto.ca/gradlife/Pages/default.aspx>



Place-holder

PLACE-HOLDER, partially funded by GALDSU through the Student Initiative Fund, was started in 2012 by students Roya Mottahedeh & Elizabeth Krasner with a desire to explore some of the trajectories that occurred around/beyond/beside architecture, and our own institutional framework. It has allowed us to be voyeurs into the after-hours work of our peers, and to mine the archives of our own alumni and faculty members at the University of Toronto. In ISSUE 00 (published 2013), we looked at what happens IN THE BUILDING, and in this one we leave the building to find out what happens AFTER SCHOOL. ISSUE 1/2 can be read both as “half” – because we are obsessed with capturing the unfinished, and also as a double issue. The first section contains all recent interviews, essays, poetry, and photos, while the second part is largely archival, unpublished work from within the faculty ten years ago. ISSUE 03 dealt with the topic of copying in the digital age and the status of the public domain in our contemporary network culture and was launched in 2016 at the Toronto Art Book Fair.

PLACE-HOLDER is always looking for new contributions from faculty, students and others -- anything outside of the polished final drawings we are so accustomed to. Please get in touch at placeholder.net@gmail.com!

The Annual

The Annual is a selection of student work from across years and programs at Daniels. Work is collected, curated, and edited entirely by students and recent graduates.

Café 059

The student-run café is a central hub of the Daniels student community and a place to take a great break to grab a coffee and a snack between classes. Students interested in volunteering at Café 059 should contact cafe059@galdsu.ca

UTSU

Daniels Faculty students at the University of Toronto are members of the University of Toronto Students' Union (UTSU). The University of Toronto Students' Union represents all 50,000 full-time undergraduate and professional faculty students at UofT's St. George and Mississauga campuses. UTSU works to build community on campus and ensure students have the best possible experience while here.

UTSU website: <http://www.utsu.ca/>

ULIFE

Visit the ULife website and find a variety of student clubs, organizations, activities, and opportunities for students. <https://www.ulife.utoronto.ca/>

Athletics and Recreation

With seven gymnasias, four pools (including the only Olympic-sized pool in downtown Toronto), a strength and conditioning centre, indoor track, dance studio, cardio machines, tennis and squash courts and steam rooms, the University of Toronto has something for everybody. Registered U of T graduate students paying compulsory athletic incidental fees are automatically members of the Athletic Centre, the Varsity Centre, and Hart House.

Athletic Centre: Houses multiple gymnasias, a 50-metre Olympic pool, 25-yard pool and 3-foot-deep teach pool, 10 squash courts (5 American and 5 British style), a dance studio, gymnastics gym, eight-lane 200-metre indoor track, tennis courts, basketball courts, strength and conditioning centre, cardio machines, spinning room, fencing sale, sport medicine clinic and golf cage.

http://www.physical.utoronto.ca/FacilitiesAndMemberships/Athletic_Centre.aspx

Hart House: Open 365 days a year and located downtown on the University of Toronto campus. Features include an art deco pool, squash courts, multi-level fitness facilities, suspended indoor track, drop-in fitness classes, registered classes and a variety of spaces for everything from basketball to archery.

<http://harthouse.ca/>

Goldring Centre for High Performance Sport: The Goldring Centre for High Performance Sport is a multi-storey sport and exercise facility housing a 2,000-seat, internationally-rated field house for basketball, volleyball and other court sports, a state-of-the-art strength and conditioning centre, fitness studio, sport medicine clinic and research and teaching laboratories.

<http://physical.utoronto.ca/FacilitiesAndMemberships/goldring-centre-for-high-performance-sport.aspx>



Programs and Registration

The John H. Daniels Faculty of Architecture, Landscape, and Design (Daniels) offers rigorous programs of study for the emerging architect, landscape architect, urban designer, forester, artist, or curator. For over 120 years, graduates of our school have spread across Canada and the world as innovators and leaders in the design and visual studies professions.

Daniels offers five areas of study at the Masters level as well as several Collaborative Programs:

- Master of Architecture
- Master of Landscape Architecture
- Master of Urban Design
- Master of Visual Studies in studio art or Curatorial Studies
- Master of Forest Conservation
- Master of Science in Forestry

Further information about each program is provided in its own designated section below.

Registration and sessional dates are officially set by the School of Graduate Studies (SGS). It is a students' responsibility to be aware of their requirements. The Daniels Faculty sets their sessional dates within the parameters of the official dates posted by SGS.

Academic Progress

It is a student's responsibility to ensure that they are successfully completing all course requirements for graduation each term; please see the appropriate curriculum listed in this package by program or the School of Graduate Studies Academic Calendar. Students must refer to ACORN for an official record of final grades and transcripts from the University of Toronto. The Registrar is available to assist students when they have questions or are experiencing any academic, personal or financial difficulties. Please contact the Registrar at any time for an appointment through the Office of the Registrar and Student Services.

To request a transcript upon completion of their program, students may order through their ACORN account. Alternatively, see the Transcript Centre website at: <http://www.transcripts.utoronto.ca/>

Registration

At the University of Toronto, there is a difference between enrolment and registration. Students enrol in courses. Students register for the academic session by paying tuition and incidental fees, or registering without payment (defer fees). Upon accepting an offer of admission, a registration status is created and a student is considered invited to the term. This generally occurs in mid-July.

Returning students who were previously registered in the last Fall/Winter or Summer academic session or who have completed an official leave of absence where the expected return session is the current Fall/Winter academic session, are automatically invited to their next year of study at the same time in mid-July. Once the registration status of 'INVITED' appears on a student's ACORN account, they have been assessed for tuition fees and can pay to register for the term. The deadline to make the minimum payment to register or defer fees for the current academic session can be found on the Graduate Sessional Dates.

Once the minimum payment to register is processed by Student Accounts (approximately 5-10 business days after the payment is made) or a fee deferral is completed, the registration status will automatically be updated to 'registered'*. Tuition fees can be found in the Financial Accounts section of a student's ACORN account.

*There are two situations where paying the minimum payment to register by the deadline will not register a student:

1. If a returning student has arrears, the arrears must be paid on top of the minimum payment in order to become registered. Students cannot register with arrears (see details under Tuition Fees).
2. Newly admitted students with a severe condition of admission attached to their offer will not automatically be registered if their severe condition is outstanding at the time the payment is processed.

Course Enrolment

Daniels Faculty graduate students will automatically be enrolled in all of their core courses with the exception of option studios, research studios, and electives; it is a students' responsibility to ensure they are in the right courses each semester by reviewing their courses on the Student Web Service (ACORN) regularly.

Electives

The number of electives a student will take will vary based on the program of study and whether a student applies for and receives course exemptions. Each year in mid-August Daniels publishes a list of the offered electives for the year.

All elective enrolment, with the exception of visual studies electives, independent study courses, and inter-departmental enrolment requests, will be completed online through ACORN account in real-time on a first-come, first-served basis. Student require their JOINid/UTORid and password in order to log in. The start time for enrolment on each designated start date is 6:00am EST (Eastern Standard Time, GMT-4). It is recommended that first-time users log in to ACORN at least one week in advance to ensure they do not experience any difficulties with accessing the student web service.

Student are assigned an enrolment start date based on cohort year of study. Upper year students will be assigned earlier start dates to ensure they are able to meet their degree requirements. Cohort year of

study can be determined by reviewing the curriculum and the diagrams of degree requirements. For example: Students starting their first year at the Daniels Faculty as a Master of Architecture student with advanced standing have a cohort year of MArch year 2.

Students who are not sure of their cohort year of study should contact registrar@daniels.utoronto.ca well in advance of the enrolment start dates. Enrolment start dates are listed as part of the Graduate Sessional dates annually.

Selecting Elective Courses

In order to determine which elective courses to take, students review the detailed elective course descriptions as they become available in the Courses section of the Daniels website. Generic descriptions of each elective offered by the Daniels Faculty are provided in this handbook. Students are encouraged to make note of several options as alternatives in case their first choice(s) become(s) full. The online descriptions will include any pre-requisites the course may have.

A step-by-step guide on how to add courses is available on the ACORN help site: <http://help.acorn.utoronto.ca/how-to/>

Independent Study

Independent Study courses are offered as an opportunity for students who wish to pursue an academically challenging project or topic that is currently not covered in the curriculum. Independent Studies are not required and are not automatically granted. Only those who have a well-developed proposal, high academic standing, and the approval from a potential advisor as well as the program director may pursue an Independent Study. Further details and deadlines are available online: <https://www.daniels.utoronto.ca/info/current-students/graduate/course-enrolment>



Master of Visual Studies Elective Offerings

For electives in the Master of Visual Studies program, students must complete the add/drop form available on the School of Graduate Studies website (www.sgs.utoronto.ca) and contact Charles Stankieveh, MVS Program Director to obtain approval. Approved forms must be signed by both the Director and student and submitted by the student to the Office of the Registrar and Student Services.

Inter-departmental Elective Offerings

To request enrolment in electives offered by other departments, students must obtain the instructor's signature and the host department coordinator/administrator's signature before submitting the add/drop request form to the Office of the Registrar and Student Services or registrar@daniels.utoronto.ca for final approval. The form can only be processed if completed correctly. Students must provide the Office of the Registrar and Student Services with contact information for the host department administrator in order to confirm approval. Please note that other department enrolment dates will differ from that of the Daniels Faculty and it is a students' responsibility to be aware of these dates and contact the departments as appropriate.

History and Theory Elective Requirement – MArch and MUD only

As part of the degree requirements for the Master of Architecture and Master of Urban Design programs, a certain number of electives must be completed from the History & Theory category. History & Theory category courses from any of the Daniels Faculty programs can be used to satisfy this requirement. Please see the School of Graduate Studies academic calendar to determine which courses will satisfy this requirement.

Maximum Session Load

Students may take a maximum session load of 5.0 full course equivalents (FCE) across the Fall/Winter academic session*. This includes pre-loaded core (required) courses. Students therefore cannot enrol in more electives over the academic session than indicated in the diagrams of degree requirements. Students who wish to overload with an additional elective must request an overload by email to registrar@daniels.utoronto.ca and include a completed School of Graduate Studies Add/Drop Request form. Please note, an approved request to overload does not guarantee placement in the course if the course is full.

**Master of Landscape Architecture students are enrolled in 5.5 FCE of core courses in their first year of study due to the Field Studies courses. These courses, each weighted 0.25 FCE, run outside the regular term and are therefore not considered an overload.*

Elective Course Waiting Lists

The Waiting List is a feature that lets students “line up” for a course that’s currently full, in case a space becomes available in the future. If a student cancels the course and the student listed first on the waitlist will be enrolled automatically. An email will be sent to the student’s U of T email account to notify them of the enrolment.

It is important to understand the following about waiting lists:

- Waitlisted courses count towards a students’ overall session load.
- In the Fall/Winter, students can be on the waiting list for up to 1.0 FCE as a full-time student (0.5 FCE per semester) and 0.5 FCE as a part- time student.
- All Daniels Faculty ARC, LAN, and URD elective courses have waiting lists. VIS electives do not.
- Waiting lists are not available for the entire duration of the enrolment period. Waiting lists will be removed according to the Graduate Sessional Dates.

It is recommended that students prepare as many alternative elective course choices as possible. Students do not have the right to be in a class for which they have not obtained successful enrolment and will not be granted late registration.

Course Conflicts

Conflicts occur when students enrol in courses that take place at the same time. When considering electives, it is important to make sure no elective courses overlap with each other or with core (required) courses in day and time. ACORN will not prevent students from enrolling in courses that conflict. Students who choose to enrol in conflicting courses must note that no special consideration or accommodation will be made for any problems that occur as a result (e.g. term tests scheduled at the same time, assignment due dates, attendance). It is a students’ responsibility to avoid conflicts in their schedule.

Cancelling/Dropping a Course

Students who decide they no longer want to take an elective course must cancel it on ACORN as soon as possible. This applies to waitlisted as well as enrolled courses. Please do not occupy a space unnecessarily. Only by cancelling the course will the space become available to another student. Students are be responsible for any academic penalties incurred by not cancelling a course(s) by the appropriate deadlines. The academic drop deadlines are listed on the website in the Graduate Sessional Dates.

Students cannot drop their core courses on ACORN. Students considering dropping a core course must book an appointment with the Registrar well in advance of the drop deadline to discuss the potential implications of their decision.

Course Exemptions

When a request is submitted, the Daniels Faculty will assess courses obtained at a post-secondary institution where a degree program has been completed for potential course exemptions. Course exemptions are granted only upon approval of the Instructor and the Program Director and are not guaranteed. Students must have achieved a grade of B or higher to be considered. Course exemptions are not transfer credits and do not reduce the total number of credits required for the degree. Each course exemption granted has a certain number of Full Course Equivalent (FCE) that must be replaced with electives totaling the same number of FCEs. Course exemptions have no credit weight. The Office of the Registrar and Student Services will process the request and will email the official decision.

The following documentation is required as a single PDF in order for previously obtained credits to be assessed for course exemption:

- One course exemption request form per course request;
- Course description as listed in the university calendar;
- Course outline distributed by the professor in class;
- (If applicable) Copies of assignments (essays, tests, etc.) completed in the course;
- (If applicable) Visual documentation of projects completed in the case of design and representation courses;
- A complete copy of the official academic transcript showing grades of courses taken.

Advanced standing and transfer credits are granted only by the Admissions Committee at the time of admission. For more information on Course Exemptions, please see the Daniels website: <https://www.daniels.utoronto.ca/info/current-students/graduate/graduate-course-exemptions>

Fees and Financial Support

Tuition Fees and Registration Deadline

The deadline by which you must pay at least the minimum required payment or defer your fees depends on whether you plan to register in the Fall-Winter term, Fall term only, or Winter term only.

Students can check their Account Invoice on the Student Web Service/ ACORN, where they will find their account balance, other account details, and a link to the fee payment and service charge billing schedules on the Student Accounts website. The Student Accounts website posts all official fee information. Please familiarize yourself with this information as it is your responsibility to fund your studies and to make yourself aware of payment deadlines.

For more information visit: <https://studentaccount.utoronto.ca>



Minimum Required Payment (MRP) to Register

Students will have the following options for registering:

- 1) Students can pay for the Fall (September-December), and Winter (January-April) sessions separately according to the timelines in the charts below
- 2) They can pay the entire Fall-Winter (Sept-April) in August
- 3) Eligible students who have an OSAP or other province government student loan application*
- 4) Students with a graduate funding package or a major award that exceeds the Minimum Payment to Register amount on their ACORN invoice are required to defer to register without payment before the end of the registration period*

*Students cannot defer their fees if they have any outstanding fees (arrears) from a previous academic session.

Detailed information, including tuition, refund schedules, and payment and service charge deadlines, is available on the Student Accounts website. General fees information can also be found on the School of Graduate Studies website.

Please read the information below that pertains to your specific situation. For information on how to make a fee payment, please visit the Student Accounts website.

Students who are not eligible to defer their fees:

Fall-Winter Registration

Arrears + 100% of Fall (September to December) tuition fees due by **September 11, 2020**.

We recommend paying or deferring by **August 28, 2020** to meet this due date.

Winter Registration

Arrears + 100% of Winter (January to April) tuition fees due by **30 November 2020**

Students who may be eligible to defer their fees on the basis of OSAP or another government loan:

Students who wish to defer their fees by the registration deadline on the basis of OSAP or another government loan must have a submitted application..

All arrears must be cleared prior to deferring fees. Students cannot defer their fees if they have any outstanding fees from a previous academic session. Residence payments cannot be deferred (delayed). Your residence occupancy agreement lists the payment due dates. Students who are receiving government funding may request to defer their fees on ACORN

Fall Term Fees
100% of Fall (September to December) tuition fees due by
30 September 2020
Winter Term Fees
100% of Winter (January to April) tuition fees due by
31 January 2020

If you have deferred your fees, full payment of fall session fees is due by September 30, 2020. Otherwise, monthly service charges at a rate of 1.5% compounded monthly (19.56% per annum) will be applied against the outstanding student account balance beginning October 15th and the subsequent 15th of every month thereafter until the account is paid in full.

Full payment of winter session fees is due by January 31, 2020. Otherwise, monthly service charges at a rate of 1.5% compounded monthly (19.56% per annum) will be applied against the outstanding student account balance beginning February 15th and the subsequent 15th of every month thereafter until the account is paid in full.

Students who may be eligible to defer their fees on the basis of an award or waiver:

Students who wish to defer their fees on the basis of their graduate funding package OR a major award OR a scholarship OR tuition waiver must submit the proper paperwork to the Office of the Registrar and Student Services.

All arrears must be cleared prior to deferring fees. Students cannot defer their fees if they have any outstanding fees from a previous academic session. Residence payments cannot be deferred (delayed). Your residence occupancy agreement lists the payment due dates. Students who are receiving award funding may request to defer their fees by submitting the School of Graduate Studies Register without Payment (Fee Deferral) form to the Daniels Faculty at 1 Spadina Crescent or by emailing registrar@daniels.utoronto.ca prior to the deadline to defer fees.

Detailed information, including tuition, refund schedules, and payment and service charge deadlines, is available on the Student Accounts website. General fees information can also be found on the School of Graduate Studies website.

After you receive your funds, you must pay at least the minimum payment to register amount on your invoice.

When planning fee payments, students receiving SGS awards should take into account that January and May award installments are credited directly to outstanding fees. Daniels Faculty awards are always credited directly to outstanding fees.

Full payment of fall and winter session fees is due by **April 30, 2021**. Otherwise, monthly service charges at a rate of 1.5% compounded monthly (19.56% per annum) will be applied against the outstanding student account balance beginning May 15th and the subsequent 15th of every month thereafter until the account is paid in full.

For more information visit: <https://studentaccount.utoronto.ca/>

Financial Support

Students in our Masters programs self-fund their education through a variety of means. Many students utilize government loan programs, UTAPs, scholarships, awards, funding packages, and personal/bank loans to finance their studies. It is a student's responsibility to ensure they have a viable financial plan for each year of study. Students are encouraged to maintain a budget and consult this website as well as the SGS website for up-to-date information about awards and financial

aid opportunities.

Money Management

This all starts with knowing what resources you have and where it is being spent. Make good decisions and take action proactively regarding your financial situation by planning early.

Always check your credit history (Online credit check — Equifax)

Make a budget and try to stick to it

Always plan for an emergency-budget in money for repairs, extra costs, and other unexpected expenses (medical/dental)

In over your head? Consider credit counseling. Here are some helpful websites:

www.InChargeCanada.ca

www.creditcounsellingcanada.ca

www.oaccs.com

When in doubt, speak with a financial aid advisor available at the School of Graduate Studies.



Daniels Faculty Awards and Scholarships

Daniels Faculty awards that require applications will have set deadlines each year and will be made available on our website. Once all applications are received, the Daniels Faculty Awards Committee conducts the selection process and shortly after, informs all applicants of the results.

It is the responsibility of each student to be aware of all important dates and to consult the appropriate webpage when applying for awards, funding, and scholarship competitions.

Daniels students are automatically considered for the majority of Daniels in-course awards* and all Daniels graduating awards. Students are notified of in-course awards in the fall and graduating awards in June. Graduating awards are presented at the Graduation Celebration immediately following Convocation in June.

*For Daniels in-course awards requiring applications, instructions are communicated directly to students during the academic term.

Graduate Resources

Graduate Government-Funded awards and other awards administered by the Graduate Awards Office at the School of Graduate Studies or by Enrolment Services may require the Daniels Faculty Awards Committee to conduct the initial selection process prior to sending top applications forward to be centrally adjudicated.

To view award competitions to see what's available through the School of Graduate Studies visit: <https://www.sgs.utoronto.ca/awards-funding/>



To speak with a financial aid counselor, or to learn about programs and services designed to help graduate students at the University of Toronto, please visit the SGS financial aid website. If you have exhausted all other means of support and still find yourself in financial difficulty, the John H. Daniels Faculty of Architecture, Landscape, and Design may be able to provide financial assistance in the form of a grant. For more information, please visit the Financial Aid page.

Daniels Award / Bursary Payment and Policies

Our priority is to provide our students with the best possible financial service in support of their educational goals. It is important to us that all our current and future students know where to begin exploring funding opportunities throughout the University and externally. Award and bursary payments are issued through ACORN and applied against any unpaid fees. Any remaining balance will be issued directly to the student as a cheque or direct deposit.

We strongly urge students to set up direct deposit by logging in to your ACORN account and adding your banking information. Direct deposit will ensure that you receive your payment(s) quickly. As well, cheques may be lost and need to be cancelled and replaced, which will result in a further delay of your payment.

Please note that you can contact Student Accounts at info.studentaccount@utoronto.ca at any time to request a refund of a credit balance. To set up direct deposit on your SWS account, follow the steps shown in the demo video, Direct Deposit in SWS.

Awards and bursaries are issued at varying times of the year dependent on the award or bursary. Please consult your letter for your payment schedule.

Students who receive departmental funding or major awards are still responsible for the payment of their fees. The department does not make tuition payments on behalf of the student (i.e., if tuition is due prior to the payment of your award or bursary, you are responsible for the minimum payment to register or appropriate deferral of your fees).

Funding Packages for Forestry Students

The Faculty's M.F.C. admission fellowships for the upcoming academic year were allocated and recipients notified individually early in the admission consideration cycle. Admission fellowship amounts will be directed to the student's fees account if fees are not paid in full at the time of registration.

Please note that your on-admission Fellowships will be paid in one installment by the Graduate Department, after your registration has been confirmed. It will be posted to your ACORN account to pay down your tuition fees. When arranging to pay your tuition fees, please

deduct this amount from your payment.

A number of smaller departmental awards for 2020-21 with specific eligibility criteria will be allocated on a competitive basis later in the year; details on eligibility and the application process and deadlines for these will be posted electronically, when available.

Note that, after commencing studies, students are urged to apply for all fellowships for which they may be eligible. In past years we have found that a number of internship opportunities require the student to possess a valid driver license.

Terms and Conditions

- Students must be registered full-time in a graduate level program in order to hold an award or bursary in the term issued. Those who withdraw or change their status (e.g., full time to part time) will no longer be eligible and will be required to repay the funds received for the incomplete term.
- A Daniels Faculty award may not be deferred or interrupted unless approved by the Faculty Registrar and Awards Committee in advance. Students should consult the Office of the Registrar and Student Services for further information if this pertains to them.
- Please note that the University of Toronto has the sole right to correct any error(s) regarding an award payment. The University of Toronto ensures that your personal and financial information is secure and handled with care.
- As an award recipient, your name, selected biographical, and/or academic information may be conveyed to the donor or their representatives. The Faculty may also choose to publicize your name (at its discretion) on the Faculty website and in other communications materials.



Responsibilities

Award or Bursary holders must:

- Accept and activate the payment of their award with the Daniels Faculty by completing, signing and submitting the Award/ Bursary Agreement Form to the Officer of the Registrar and Student Services. Payment activation is conditional upon the receipt of this completed form.
- Abide by all conditions of eligibility and acceptance that govern the award for its full duration. Students who fail to meet or maintain any condition of the award will forfeit the remainder of its funds and be required to repay any payments that might have been received while they were ineligible.
- Inform the Office of the Registrar and Student Services of any change to their registration status (e.g., withdrawal from the program, leave of absence, transfer to part-time status, change in program of study or early completion of the program).
- Maintain accurate and current mailing information on the Student Web Service (ACORN) at www.acorn.utoronto.ca since ACORN will not be able to process payment of the award or bursary if the recipient's mailing address has expired.

Award holders are encouraged to take the opportunity to write a thank you note to the donor of the award they receive.

Award recipients are recognized for their contributions to the Daniels Faculty and are expected, as are all Daniels students, to present themselves in a professional manner when interacting with Donors, Faculty, Staff and the greater community to help contribute to the positive image of the Faculty.

Please check your award or bursary offer letter to find out if there are any additional terms and conditions you must meet to accept your award or bursary.

Financial Aid

The main source of financial aid for students is the federally and provincially funded Ontario Student Assistance Program (OSAP). Application forms are available after April 1 at the School of Graduate Studies, Student Services Office.

Bursaries and Emergency Loans

If you have exhausted all other means of support and still find yourself in financial difficulty, the John H. Daniels Faculty of Architecture, Landscape, and Design can provide financial assistance in the form of a grant. The Faculty grants do not replace OSAP or UTAPS; the grants help to alleviate temporary financial setbacks.

If you are not eligible for OSAP, you may still apply for Faculty grants; however, please keep in mind that resources are limited. Grant applications are being accepted now. Please read the information below carefully, and completed forms should be submitted to the Office of the Registrar and Student Services.

A limited amount of emergency assistance is also available on a case-

by-case basis through the School of Graduate Studies' bursary and emergency loan programs. For more information, please see the School of Graduate Studies website.

Employment Opportunities

The Daniels faculty advertises CUPE positions for Teaching Assistants, Chief Presiding Officers, and Invigilators. These positions are posted as needed for Daniels Faculty courses/final examinations in accordance with the respective CUPE local 3902 Collective Agreement. Daniels staff and faculty also post work study positions through the Career Centre for administrative and research assistant positions. In addition to the jobs offered by the Daniels Faculty, students are encouraged to apply for positions throughout the University.

Teaching Assistantships

The John H. Daniels Faculty of Architecture, Landscape, and Design offers a variety of Teaching Assistantship positions each session for both graduate and undergraduate courses. Hiring priority is given to graduate students with first consideration given to graduate students with prior experience. Students are expected to ensure that the Teaching Assistant positions they have applied to do not conflict with their core courses. Students may be expected to attend a combination of Lectures, Practicals, and Tutorials, depending on the course.

Students are expected to choose electives that will not conflict with their Teaching Assistantship obligations.

Decisions will be communicated via valid UofT email addresses. Fall Teaching Assistant offers will go out early August. Winter Teaching Assistant offers will go out later in the Fall.

All jobs are posted in accordance with the CUPE Local 3902, Unit 1 Collective Agreement. Any questions should be sent to ta@daniels.utoronto.ca

Chief Presiding Officers and Invigilators

The John H. Daniels Faculty of Architecture, Landscape, and Design hires Chief Presiding Officers and Invigilators to preside over final examinations held in the examination period of each academic term as required. Chief Presiding Officers will act on behalf of the Office of the Registrar and Student Services in administering Faculty final examinations in strict accordance with Faculty procedures and regulations. They will be responsible for picking up examination materials; opening and organizing examination rooms; making announcements; distributing examination books and question papers; collecting student signatures; dealing with emergency situations such as ill students, fire alarms, etc.; returning materials to the Office of the Registrar and Student Services; maintaining the confidentiality of examination materials; and carrying out the directives contained in the procedures and regulations governing Faculty final examinations. Occasional attendance at meetings and tribunals is required.

Qualifications

Positions are available only to students enrolled in the School of

Graduate Studies at the University of Toronto. First consideration will be given to graduate students with experience in conducting Faculty final examinations. General qualifications include: ability to carry out procedures under pressure using tact and judgment, ability to effectively direct large groups, and ability to communicate clearly and effectively.

Application Procedure

Application forms, to which a resume may be attached are available online. Application deadlines are communicated to students.

Work-study and Other On-Campus Positions

Working on campus throughout the school year, or over the summer, can be a great way to explore different careers, build skills that you enjoy using, make some extra money and get experience that will impress employers. Please visit the Career Centre website for available on-campus work opportunities. Applications are now being accepted for a variety of opportunities. <https://clnx.utoronto.ca/students/wspublicstudents.htm>

Regulations and Policies

The University has policies and procedures that are approved by the Governing Council which apply to all students. Each student must become familiar with these policies. The Faculty follows the regulations and policies as described in the School of Graduate Studies Calendar including: Student Code of Conduct, Code of Behaviour on Academic Matters, Grading Practices Policy and Policy on Official Correspondence with Students. For more information about students' rights and responsibilities visit <https://www.viceprovoststudents.utoronto.ca/students/>



Master of Architecture

Overview

Daniels offers two degree options in the Master of Architecture (MArch): a first professional program and a post-professional option.

The professional Master of Architecture is a rigorous and comprehensive program, preparing graduates for the full range of activities in architecture. It provides a thorough base of knowledge in history, theory, technology, ecology, society, and professional practice, while developing skills in design through an intensive sequence of design studio courses. There are six streams: Design (7 courses), Computer Modelling (1 course), Visual Communication (2 courses), History & Theory (3 courses), Technics & Planning (7 courses), and Professional Practice (1 course). Studios are supported by courses in visual communication and architectural representation, including computer modelling and other new media. The program aims to develop critical, creative, and independent thinking and research that responds to current design issues and societal changes. The greater Toronto region is used as an urban laboratory for the pursuit of new knowledge and new forms of practice.

The Daniels Faculty also offers a Master of Architecture Second-Year Advanced-Standing Option (2 years). The Advanced-Standing Option is offered to applicants who demonstrate advanced capabilities, as determined through review of academic background and design portfolio. Advanced-Standing students join the curriculum outlined below at the beginning of the second year of study.

Both the MArch and the Advanced-Standing Option are intended for those who do not already hold a professional degree in architecture.

Individuals already holding a professional degree are encouraged to consider the post-professional Master of Architecture option or the Master of Urban Design program.

Those wishing to verify the status in Canada of a professional architecture degree earned abroad should contact the Canadian Architectural Certification Board (CACB): info@cacb.ca. If the CACB recognizes your degree as equivalent to a Canadian degree, you will not be eligible to apply for our professional MArch program.

For more information on degree requirements visit <https://sgs.calendar.utoronto.ca/degree/Architecture,-Landscape,-and-Design>

Master of Architecture Degree Requirements

For students enrolled in September 2020 and later. Sample degree chart included below, please note your enrollment may not exactly match the chart below due to curriculum adjustments/covid19.

	YEAR 1	YEAR 2**	YEAR 3**	
AUGUST INTENSIVE	ARC 1021H Visual Communications (0.5 FCE)	ARC 1042H Site Engineering & Ecology (0.5 FCE)		
	ARC 1011YF Design Studio 1 (1.0 FCE)	ARC 2013YF Design Studio 3 (1.0 FCE)	ARC 3020YF Design Studio Research 1 (1.0 FCE)	
FALL SEMESTER	ARC 1022HF Design Technology 1 (0.5 FCE)	ARC 2023HF Design Technology 2 (0.5 FCE)	ARC 3051H Professional Practice 1 (0.5 FCE)	
	ARC 1031HF Historical Pers. On Topics In Arch. 1 (0.5 FCE)	ARC 2047HF Building Science 3 (0.5 FCE)	ELECTIVE* (0.5 FCE)	
	ARC 1041HF Building Science 1 (0.5 FCE)	ARC 2017HF Research Methods (0.5 FCE)	ELECTIVE* (0.5 FCE)	
WINTER SEMESTER	ARC 1012YS Design Studio 2 (1.0 FCE)	ARC 2014YS Design Studio 4 (1.0 FCE)	ARC 3021YS Design Studio Research 2 (1.0 FCE)	Notes * 0.5 FCE full course equivalents (FCE) of elective courses must be in the History and Theory Stream. ** 2.0 year program: Second year advanced standing option.
	ARC 1046HS Structures 1 (0.5 FCE)	ARC 2046HS Structures 2 (0.5 FCE)	ARC 3052YS Professional Practice 2 (1.0 FCE)	
	ARC 1032HS Historical Pers. On Topics in Arch 2 (0.5 FCE)	ARC 2045HS Building Science 4 (0.5 FCE)	ELECTIVE* (0.5 FCE)	
	ARC 1043HS Building Science 2 (0.5 FCE)	ELECTIVE* (0.5 FCE)	ELECTIVE* (0.5 FCE)	
	5.5 FCE	5.5 FCE	5.0 FCE	2.0 Year Program** = 10.5 FCE
				= 16.0 FCE

Post-Professional MArch Requirements

Notes

The prerequisite for entry into the post-professional MArch is possession of an accredited professional degree in architecture from the University of Toronto or its equivalent from a recognized university. The post-professional Master of Architecture does not grant a professionally accredited degree; rather, a professional degree is a prerequisite for admission. Those wishing to verify the status in Canada of a professional architecture degree earned abroad should contact the Canadian Architectural Certification Board (CACB): info@cacb.ca.

More information on admissions is available on our Graduate Admissions webpage.

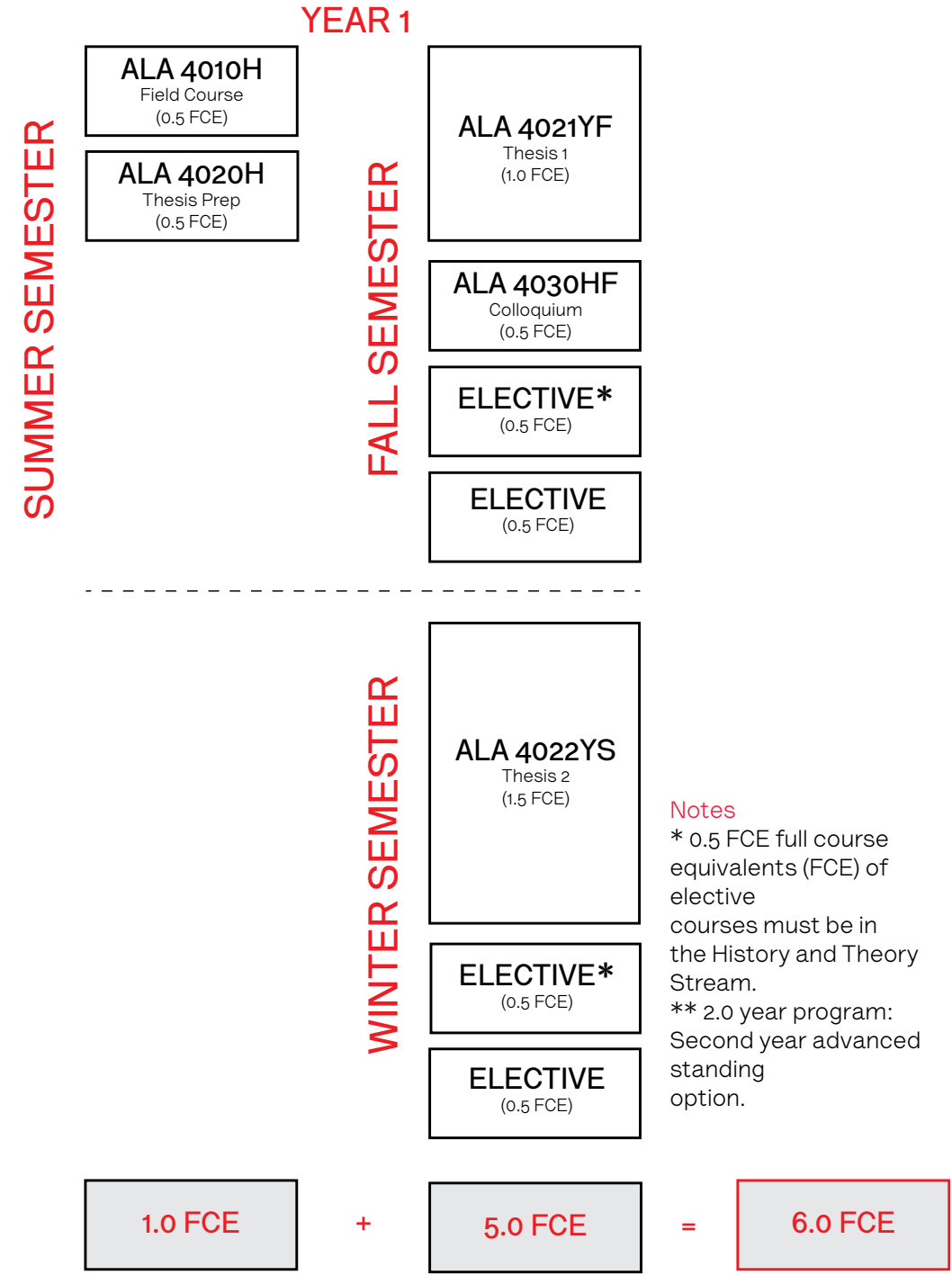

Notes
 * 0.5 FCE full course equivalents (FCE) of elective courses must be in the History and Theory Stream.
 ** 2.0 year program: Second year advanced standing option.



Master of Landscape Architecture

Overview

Daniels offers two degree options in the Master of Landscape Architecture (MLA): a first professional program and a post-professional option.

The professional Master of Landscape Architecture degree, for students new to the discipline, uses intensive studio-based courses to address the design challenges facing urban landscapes today. Complementary lecture and seminar courses in history, theory, technology, and environmental studies provide comprehensive professional training and serve as a forum to examine landscape architecture's synthetic role in design and planning at scales ranging from the garden to the region. After a four-term core curriculum, students develop independent research directions that culminate in the final term's thesis studio. The program's goal is to develop progressive models for landscape architecture practice: we encourage work that explores and extends the discipline's ties to the humanities, environmental and social sciences, and engineering.

Individuals already holding a professional degree are encouraged to consider the post-professional Master of Landscape Architecture option or the Master of Urban Design program. Applicants holding an undergraduate or graduate degree in architecture, architectural design, architectural engineering, environmental design, or equivalent will be considered for the second year advanced standing option in the MLA. This decision is made on a case by case basis by the admissions committee based upon a review of the design portfolio in light of the candidate's academic and professional experience.

Both the MLA and the Advanced-Standing Option are intended for those who do not already hold a professional degree in landscape architecture.

For more information on degree requirements visit <https://sgs.calendar.utoronto.ca/degree/Architecture,-Landscape,-and-Design>

Master of Landscape Architecture Degree Requirements

For students enrolled in September 2018 and later. Sample degree chart included below, please note your enrollment may not exactly match the chart below due to curriculum adjustments/covid19.

	FIELD COURSES**	YEAR 1	YEAR 2**	YEAR 3**		
FALL SEMESTER	LAN 1041HF* Field Studies 1 (0.25 FCE)	LAN 1011YF Design Studio 1 (1.0 FCE)	LAN 2013YF Design Studio 3 (1.0 FCE)	LAN 3016YF/ URD 2013YF/ ARC 3015YF Design Studio Options (1.0 FCE)	Notes *One week intensive field course worth 0.25 full course equivalents (FCE). Field studies 1 is typically held prior to Labour Day weekend and Field Studies 2 is typically held at the end of April. ** Two year program: Second year advanced standing option. All students are required to take both field studies courses.	
		LAN 1021HF Visual Communication 1 (0.5 FCE)	LAN 2037HF Contemporary Landscape Theory (0.5 FCE)	LAN 3025HF Advanced Visual Communication (0.5 FCE)		
		LAN 1031HF History Theory Criticism 1 (0.5 FCE)	LAN 2042HF Lan. Mat., Assembly, Tech (0.5 FCE)	LAN 3051HF Lan. Research Methods (0.5 FCE)		
		LAN 1037HF Plants and Design 1 (0.25 FCE)	LAN 2045HF Landscape Ecology 1 (0.25 FCE)	LAN 3052HF Professional Practice (0.5 FCE)		
		LAN 1047HF Site Engineering 1 (0.25 FCE)	LAN 2047HF Landscape Hydrology 1 (0.25 FCE)			
	WINTER SEMESTER	LAN 1043HS* Field Studies 2 (0.25 FCE)	LAN 1012YS Design Studio 2 (1.0 FCE)	LAN 2014YS Design Studio 4 (1.0 FCE)		LAN 3017YS Design Studio Thesis (1.5 FCE)
			LAN 1022HS Visual Communication 2 (0.5 FCE)	LAN 2023HS Intermediate Visual Communication (0.5 FCE)		LAN 3045HS Advanced Site Technologies (0.5 FCE)
			LAN 1032HS History Theory Criticism 2 (0.5 FCE)	LAN 2046HS Landscape Ecology 2 (0.25 FCE)		ELECTIVE (0.5 FCE)
			LAN 1038HS Plants and Design 2 (0.25 FCE)	LAN 2048HS Landscape Hydrology 2 (0.25 FCE)		
			LAN 1048HS Site Engineering 2 (0.25 FCE)	ELECTIVE (0.5 FCE)		
	0.5 FCE	5.0 FCE	5.0 FCE	5.0 FCE	2 Year Program** = 10.5 Credits = 15.5 Credits	

Post-professional MLA Requirements

Notes

The prerequisite for entry into the post-professional MLA is possession of an accredited professional degree in landscape architecture with a final year average of at least mid-B from the University of Toronto or its equivalent from a recognized university. The course of study includes 5.0 credits over two semesters (1.0 academic years) of study including advanced visual communication (0.5), thesis preparation and research (0.5), a design studio option (1.0), a design or research thesis (1.5), and three elective courses (0.5 each). The post-professional MLA does not grant a professional degree; rather, a professional degree is a prerequisite for admission.

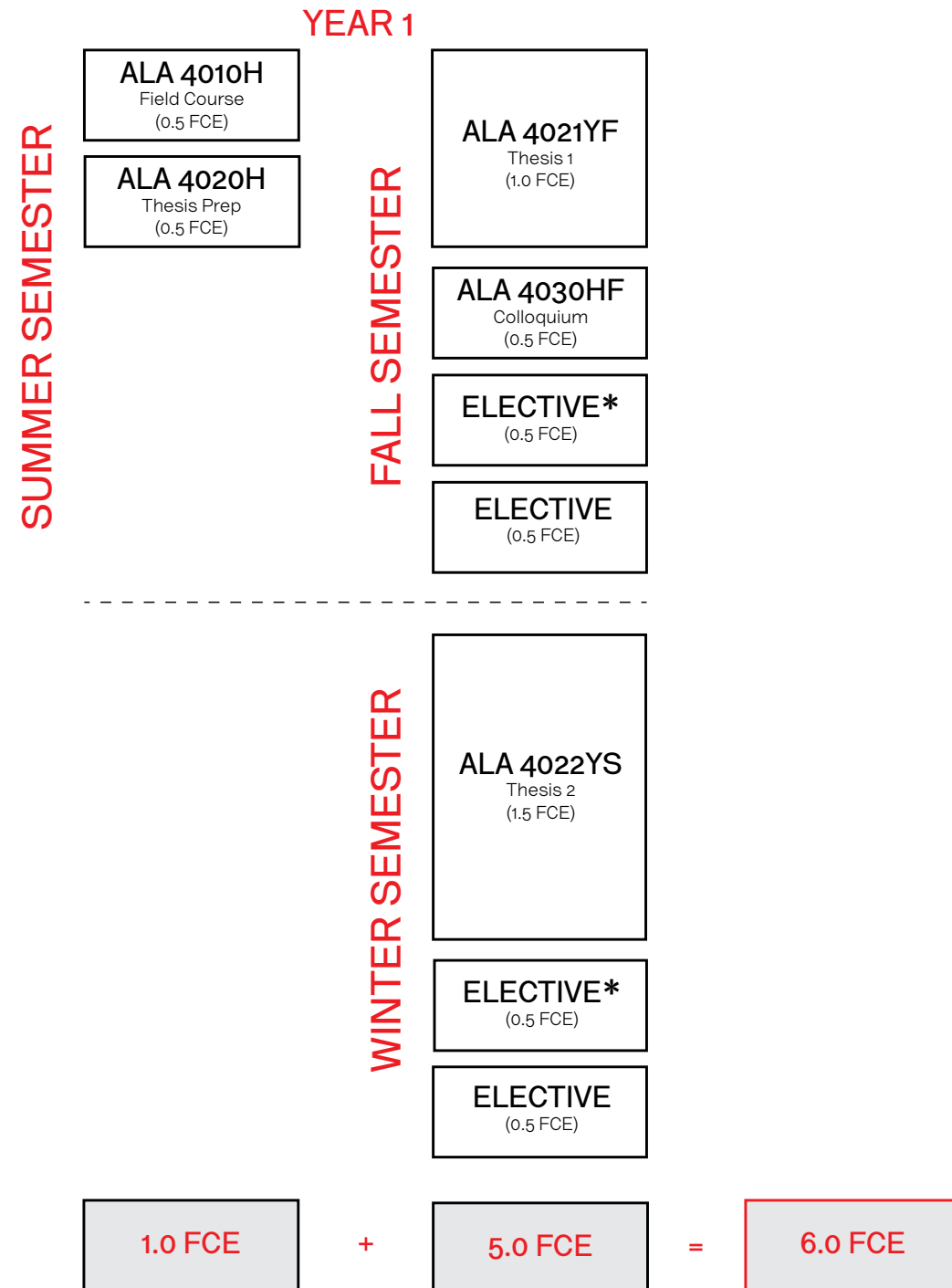

Master of Urban Design

Overview

The Master of Urban Design (MUD) program prepares architects and landscape architects for design-based research and professional practice at the urban and regional scales.

The MUD curriculum capitalizes on the wealth of resources at the University of Toronto to establish interdisciplinary and inter-professional collaboration, initiating forms of research and practice that are suited to the breadth of urban design. The program also draws on the largest pool of expertise and talent in Canada by involving leading figures of the Toronto urban design community in teaching, external reviews, and special events.

The MUD program is committed to design as a primary medium of operation and research, in a broad intellectual framework that includes geography, environmental studies, social sciences, media studies, economics, and engineering. It aims for responsible and creative design in the context of the post-metropolis, with attention to new paradigms of urbanization, global economic restructuring, and information technology. The program emphasizes a coherent intellectual approach that is committed to analysis and critique and seeks to become the central Canadian forum for advanced research, design innovation, scholarship, criticism, and debate in urban design.

The Master of Urban Design is a two-year post-professional program open to those with a professional degree in architecture (BArch, MArch) or landscape architecture (BLA, MLA) — and to others such as those with degrees in Urban Planning who have demonstrated design ability and experience — with a final year average of at least mid-B from the University of Toronto or its equivalent from a recognized university.

For more information on degree requirements visit <https://sgs.calendar.utoronto.ca/degree/Architecture,-Landscape,-and-Design>

Master of Urban Design Degree Requirements

Sample degree chart included below, please note your enrollment may not exactly match the chart below due to curriculum adjustments/ covid19.

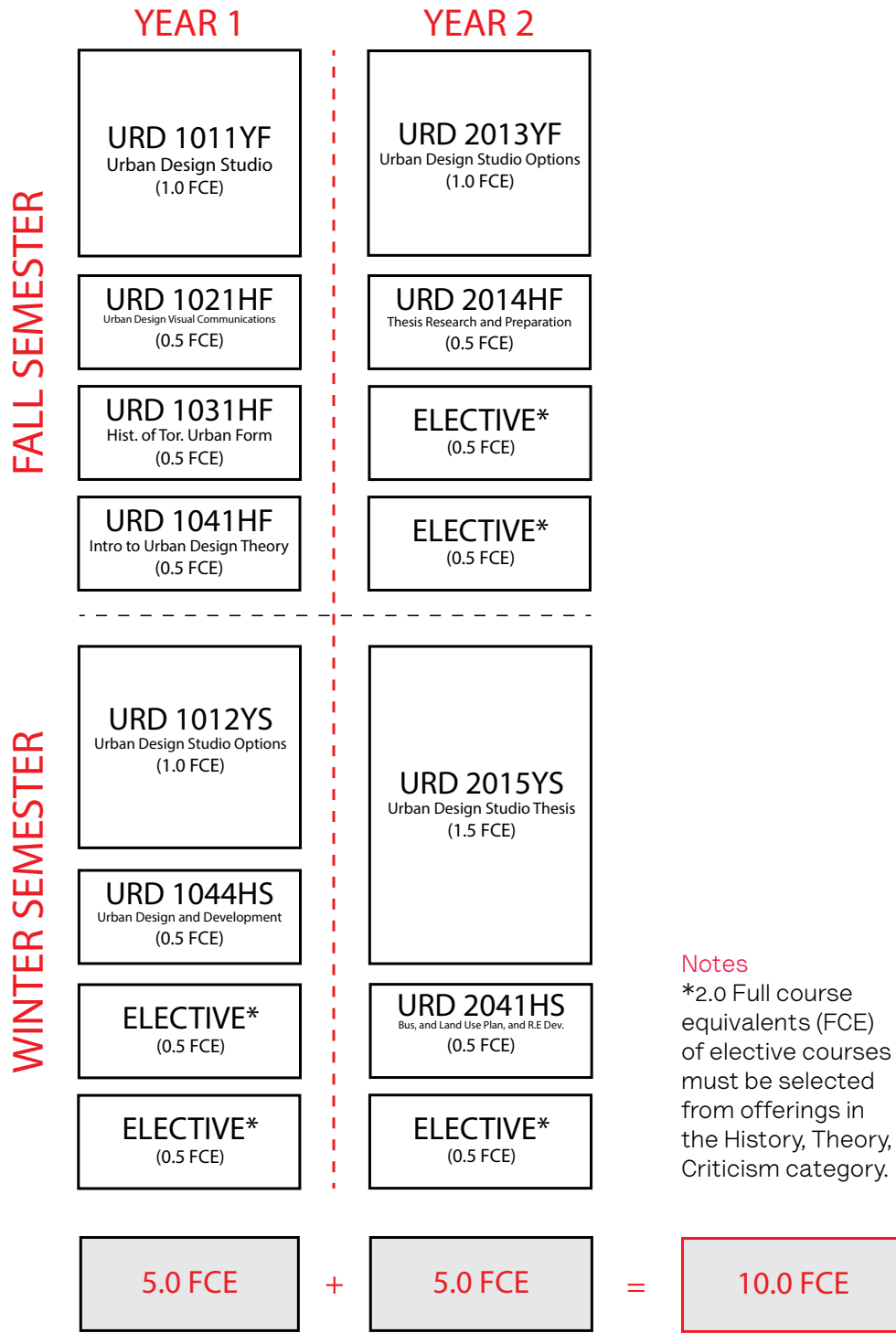

Master of Visual Studies

Overview

The MVS is a 2 year, full-time professional program featuring study in two distinct but related fields – Studio Art and Curatorial Studies. MVS Studio and Curatorial Studies students share core seminars in the theory and history of contemporary visual art in both years of study, but otherwise pursue their separate fields through focused studio/practicum sessions under the supervision of MVS studio and curatorial studies faculty respectively. In the curatorial studies field, students also work with professional curators and critics, as well as faculty from disciplines related to their course of study (see below). Students in both fields take a number of electives in other graduate units of the University and complete an internship placement aimed to further the participant's research and forge connections to outside institutions.

The MVS students will be a group of artists and curators whose work will advance knowledge within visual culture and strengthen the connections between the visual arts and other fields of study at the University and beyond. The MVS offers participants a unique opportunity to rigorously investigate the interdisciplinary components inherent in contemporary art and curatorial practice, as well as in critical writing, art theory, art history and related areas requiring a high degree of visual literacy.

The MVS produces graduates well equipped to meet the numerous overlapping skills currently demanded within professional studio art or curatorial practice, as well as critical writing, and theoretical discourse.

This program is especially suited to the city of Toronto, which offers a rich and varied cultural environment along with the potential for specific links with the Art Gallery of Ontario, the Power Plant, MOCCA (Museum of Contemporary Canadian Art) and the professional and artist-run alternative gallery systems and art-centered publications. Indeed, this program's location in Toronto provides an intellectual and artistic context for advanced study unequalled in Canada. Located in the culturally diverse city of Toronto, the MVS will be of interest to participants with backgrounds in humanities and social science disciplines: Studio Art, Visual Studies, Art History, Museum Studies, Women and Gender Studies, Anthropology, Architecture, Comparative Literature, Cinema Studies, Environmental Studies, Diaspora and Transnational Studies, and Drama.

MVS Visiting Artists and Scholars

The MVS Visiting Artists and Scholars program insures contact with the latest developments in contemporary art and critical practice, inviting Canadian and international visitors to conduct individual and group critiques with MVS participants. The bi-weekly non-credit MVS Proseminar brings artists, curators, writers, architects and scholars from other research areas at the University into a lively discussion of current works-in-progress with all the MVS students.

For more information on degree requirements visit <https://sgs.calendar.utoronto.ca/degree/Architecture,-Landscape,-and-Design>

Internship

Between the first and second year of the MVS program, all students complete an Internship placement that complements their research in either studio OR curatorial practice. Placements can be within institutions and organizations or can be directed towards work with individual arts professionals and can be located in Toronto or in other Canadian or international locations. For the Internship credit, students work with the Program Director to secure an appropriate placement. A Letter of Agreement is drawn up by the Program Director that includes a description of the work, activity, project to be undertaken during the Internship, the time frame and the contribution the host organization will provide, as well as the name of the person acting as the supervisor for the Internship credit. This must be signed by the sponsoring organization, the Visual Studies Program Director and the student before the Internship can begin.

“Show & Tell” in September

Monday, September 14, 2015 5:30 – 7:30pm Room 229, North Borden
All in-coming MVS students (studio and curatorial) will do a 10-15 minute presentation to acquaint the faculty and MVS students with the work you have done in the past and then do a sentence or two about what your planned program of work in the first year of the MVS will be.

Enhanced Tutorials for 1st Year Undergraduates

All MVS Studio and Curatorial students are asked to present an illustrated talk about their own practice (as artists or curators) to the Visual Studies first year undergraduates during the winter term. The exact schedule for these Enhanced Tutorials will be worked out during the fall term. The purpose of the Enhanced Tutorials is twofold: first, it is a good way to provide information about contemporary art and artists to the undergraduates and, second, it is an opportunity for all MVS students to develop a talk about their own work that can be useful later on if invited to present or speak by a gallery or school.

For more information on degree requirements visit <https://www.daniels.utoronto.ca/info/current-students/graduate/degree-requirements>

MVS Studio Art

Overview

The MVS Studio experience evolves within a rich environment structured around new approaches to visual art production, art theory, critical writing and professional practice. The MVS Studio faculty is comprised entirely of visual artists, with significant on-going exhibition careers. MVS Studio students pursue a highly focused investigation within studio practice along with research into contemporary theories exploring the visual and spatial relationships within art and cultural production.

The MVS Studio is concerned with the increasingly complex modes of visual expression through combinations of text, image, movement, sound and dynamic new electronic media. Accordingly, the participants will examine contemporary art practice and theory through core courses that will give them ample opportunity to develop skills in a variety of projects and media.

Multi-disciplinary and Interdisciplinary

The MVS Studio encourages both a multi-disciplinary and an interdisciplinary studio practice for our students. A multi-disciplinary art practice is one that incorporates a variety of media in its conception and production, crossing, combining or hybridizing art disciplines in its expression. This includes a variety of new and traditional media - video, installation, print technologies, photography, performance, painting and digital technologies – and produces a professional practice unique to contemporary art. As well, we expect MVS participants to benefit from the extensive resources available to them in other graduate programs at the University, including those in History of Art, Museum Studies, History, English, Drama, Comparative Literature, and Computer Science, thus offering a rich environment for interdisciplinary research and collaboration.

While all studio/practicum panels are chaired by MVS faculty, MVS Studio students are encouraged to invite University of Toronto graduate faculty from other departments to join their panels, expanding the possibilities for interdisciplinary exchange, research and production.

Graduating Exhibition and Qualifying Paper: MVS Studio

Throughout the final year of the MVS program, participants in the Studio field develop and produce a body of work that forms the basis for the graduating exhibition, scheduled for early April of the graduating year. Studio participants will benefit from working with a professional curator throughout the last term of their studies; the curator advises on installation and produces curatorial essays on each participant's work which are then printed in the catalogue for the exhibition. Final critiques and oral defense of the qualifying paper are conducted on-site in the exhibition with the participants' full panel of advisors. The qualifying paper (12-15 pages) will demonstrate the theoretical basis for the artworks produced during the MVS, detailing the research undertaken and discussing the relevance of the participant's chosen media. The qualifying paper will include a full bibliography.

Responsibilities of the Principal Advisor

The PA will review student's written summaries of the discussions of the panel during the critiques and will accept or suggest revisions. A copy is kept on file in the Program Director's office and then passed on to the student. The Principle Advisor also polls the panel and arrives at a mark for each term's studio/practicum work.

First Term Studio Practicum / Critique mark based on proposal and presentation at the end of term:

- Completeness of proposal
- Relevance of proposed or actual research to the proposed studio work
- Degree of interdisciplinary (or as it is sometimes called "intermedia") practice evident in the proposed body of work
- Quality of studio work-in-progress
- Quality of expanded written document about studio work

Second Term Studio Practicum / Critique mark based on revised proposal presented in February and final projects presented in at the end of term:

- Student's ability to experiment (with media, form, presentation) in balance with the completion of the work
- Evidence of the student's research in the finished work(s)
- Degree of interdisciplinarity (or as it is sometimes call "intermedia") practice evident in the work presented
- Over-all quality of work presented
- Clarity of artist's statement
- If necessary, student's fulfilling of panel's stated criteria as previously negotiated with student (see above)

MVS Studio Art Degree Requirements

	YEAR 1	YEAR 2
FALL SEMESTER	VIS 1010HF Contemporary Art Since 1960 (0.5 FCE)	VIS 2001HF Studio Practicum/ Critiques 3 (0.5 FCE)
	VIS 1001HF Interdisciplinary Studio Practicum/ Critiques 1 (0.5 FCE)	VIS 2002HF MVS Contemporary Art Issues (0.5 FCE)
	ELECTIVE* (0.5 FCE)	ELECTIVE* (0.5 FCE)
	VIS 1000Y MVS Proseminar (0.0 FCE)	VIS 2000Y MVS Proseminar (0.0 FCE)
WINTER SEMESTER	VIS 1020HS Contemporary Art: Theory & Criticism (0.5 FCE)	VIS 2003YS MVS Project Culminating in an Exhibition in one of the professional galleries on Campus (1.0 FCE)
	VIS 1003HS Interdisciplinary Studio Practicum/ Critiques 2 (0.5 FCE)	VIS 2000Y MVS Proseminar (0.0 FCE)
	ELECTIVE* (0.5 FCE)	
	VIS 1000Y MVS Proseminar (0.0 FCE)	
SUMMER SEMESTER	VIS 1004H** Internship (0.5 FCE)	
	3.5 FCE	2.5 FCE = 6.0 FCE

Notes
*1.0 Full course equivalents (FCE) at the graduate level in a discipline relevant to the study and production of contemporary art, selected in consultation with the student's advisor and subject to the approval of the MVS Program Director.

**An internship at a cultural institution taking place during May-August between the first and second year of study.

MVS Curatorial Studies

Overview

The MVS Curatorial Studies Program experience evolves within a rich environment structured around historical and contemporary approaches to curatorial practices, in conjunction with developments in the visual art, theory, and critical writing. In particular, MVS Curatorial Studies student will be focusing on the presentational challenges arising from complex modes of visual expression -- from object to installation, from text and image combination, temporal as well as audio and new electronic media – within the increasingly dominant forces of the culture industry.

Guided by MVS Curatorial Studies faculty, which comprises the Director of Curatorial Studies and MVS Visual Studies faculty, as well as scholars in diverse disciplines and professionals in the field, program participants will examine the history and practical skills of exhibition-making in conjunction with studies of the developments of contemporary art and theory through core and electives courses. The course of study is designed to offer students ample opportunity for the in-depth development of the subject and contents of the Graduating Exhibition, its full realization for public presentation, and the Qualifying Paper in the form of a Catalogue Essay. The Graduating Exhibition will take place within one of several, nationally and internationally renowned University of Toronto galleries of contemporary art (Justina M. Barnicke Gallery at Hart House, Blackwood Gallery at UTM, or Doris McCarthy Gallery at UTSC) but may also be developed in offsite locations, including museums and galleries within the region.

Interdisciplinarity

The MVS Curatorial Studies Program explores the multi-faceted approaches of contemporary curatorial undertakings in an interdisciplinary and international context. The aim of the program is to develop the intellectual and practical capacities for creating meaning through established and new formats of exhibition making, underscored by a wide variety of disciplines critical to the understanding of contemporary art and its presentation. We expect MVS participants to benefit from the extensive resources available to them in other graduate programs at the University, including those in History of Art, Museum Studies, History, English, Architecture, Women and Gender Studies, Diaspora and Transnational Studies, Semiotics, and Comparative Literature, thus offering a rich environment for interdisciplinary research.

While all Curatorial Studies panels are chaired by MVS faculty, MVS Curatorial Studies students are encouraged to invite University of Toronto graduate faculty from other departments as well as independent scholars and professionals to join their panels, expanding the possibilities for interdisciplinary exchange, research, and development of an intellectual and professional network.

Responsibilities of the Principal Advisor

The PA will review student's written summaries of the discussions of the panel during the critiques and will accept or suggest revisions. A copy is kept on file in the Program Director's office and passed on

to the student. The PA also polls the panel and arrives at a mark for each term's curatorial/practicum work.

First Term mark based on proposal, writings, as well as presentation at the end of term:

- Completeness of proposal
- Curatorial merit such as originality of concept and selection of works
- Quality of research
- Quality of presentation
- Evidence of supporting history and theory (integration of relevant work in related fields and interdisciplinary context)

Second Term mark is based on revised proposal and completion of the exhibition:

- Curatorial merit (originality, knowledge, supporting research)
- Quality of the installation as a public presentation (vis-à-vis the concept and art works)
- Completeness and Quality of texts (integration of relevant work in related fields and interdisciplinary context)
- Quality of logistical execution and knowledge
- Level of Professionalism achieved

MVS Curatorial Studies Degree Requirements

Sample degree chart included below, please note your enrollment may not exactly match the chart below due to curriculum adjustments/ covid19.

	YEAR 1	YEAR 2	
FALL SEMESTER	VIS 1010HF Contemporary Art Since 1960 (0.5 FCE)	VIS 2002HF MVS Contemporary Art Issues (0.5 FCE)	
	VIS 1101HF Paradigmatic Exhibitions Hist. Theory & Crit (0.5 FCE)	VIS 2102HF Curatorial Collaboration (0.5 FCE)	
	ELECTIVE* (0.5 FCE)	ELECTIVE* (0.5 FCE)	
WINTER SEMESTER	VIS 1000Y MVS Proseminar (0.0 FCE)	VIS 2000Y MVS Proseminar (0.0 FCE)	
	VIS 1020HS Contemporary Art: Theory & Criticism (0.5 FCE)	VIS 2101YS Curatorial Studies Exhibition Culminating in an Exhibition (1.0 FCE)	
	VIS 1102HS Curatorial Studies Exhibition Research (0.5 FCE)	VIS 2000Y MVS Proseminar (0.0 FCE)	<p>Notes</p> <p>*1.0 Full course equivalents (FCE) at the graduate level in a discipline relevant to the study and production of contemporary art, selected in consultation with the student's advisor and subject to the approval of the MVS Program Director.</p> <p>**An internship at a cultural institution taking place during May-August between first and second year of study.</p>
	ELECTIVE* (0.5 FCE)		
SUMMER SEMESTER	VIS 1000Y MVS Proseminar (0.0 FCE)		
	VIS 1004HF** Internship (0.5 FCE)		
	3.5 FCE	+ 2.5 FCE	= 6.0 FCE

Master of Forest Conservation

Overview

Our pioneering Master of Forest Conservation (MFC) program will enable you to make a difference by entering into professions responsible for the policies and practices that have a profound impact on all living organisms and on the sustainability of human social and economic systems; work that is crucial to society and the planet's health.

The MFC program is accredited by the Canadian Forestry Accreditation Board. Accreditation by an external body ensures that our students graduate with the competencies required to practice professional forestry.

Over a course-intensive 16-month program, you will study all aspects of forest conservation including sustainable forest management, urban forestry, forest economics, forest governance and policy, forest and wildlife conservation biology, silviculture, and current issues in forest conservation in Canada and around the world. MFC graduates can feel confident in their knowledge of forestry and conservation issues and methods and in their ability to think analytically, write and speak clearly and convincingly about complex issues and ideas, work effectively in groups of people with sometimes disparate views, and critically assess and apply information.

For more information on degree requirements visit <https://sgs.calendar.utoronto.ca/degree/Architecture,-Landscape,-and-Design>

Master of Forest Conservation Degree Requirements

Sample degree chart included below, please note your enrollment may not exactly match the chart below due to curriculum adjustments/ covid19.

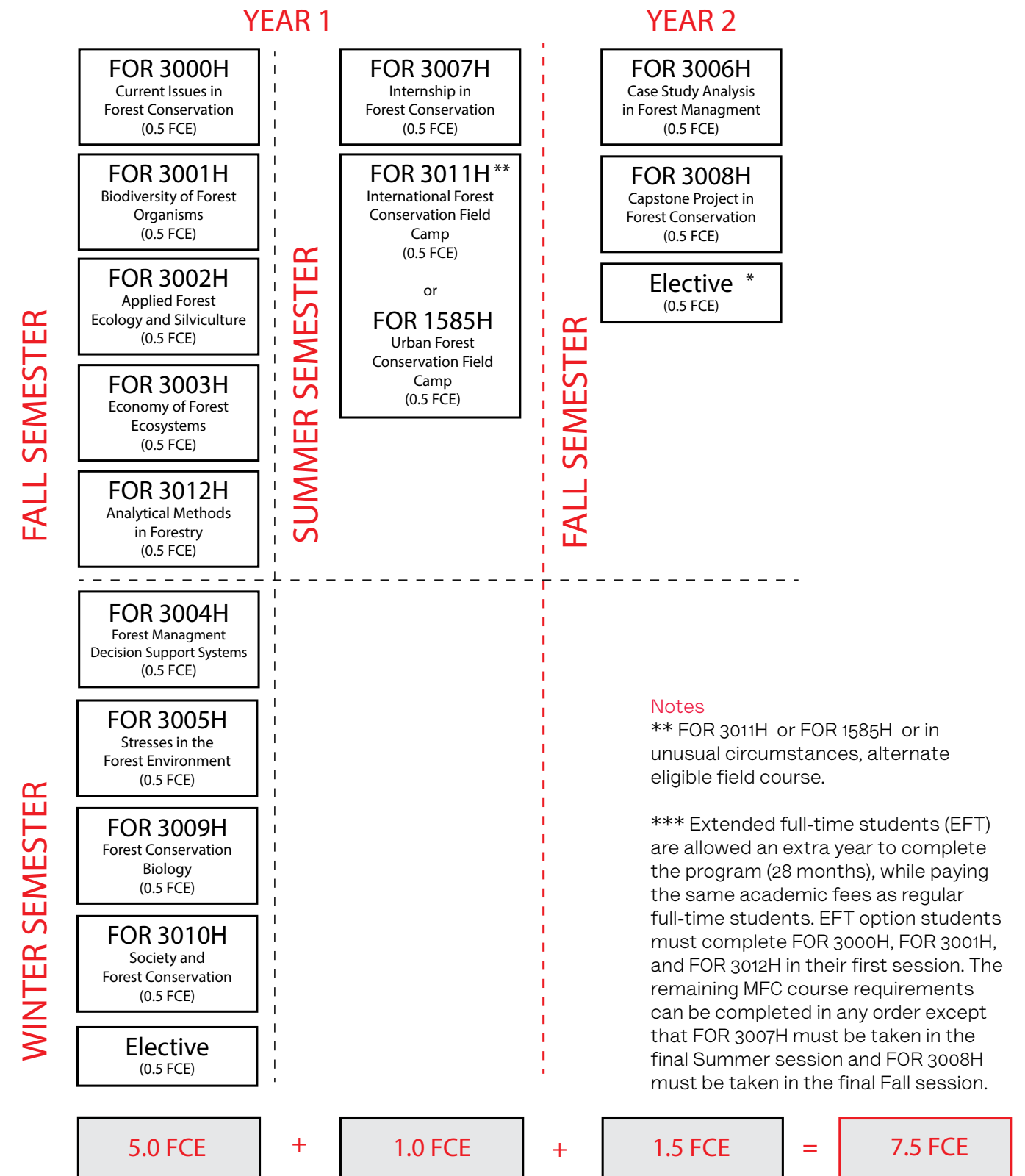

Notes
 ** FOR 3011H or FOR 1585H or in unusual circumstances, alternate eligible field course.

*** Extended full-time students (EFT) are allowed an extra year to complete the program (28 months), while paying the same academic fees as regular full-time students. EFT option students must complete FOR 3000H, FOR 3001H, and FOR 3012H in their first session. The remaining MFC course requirements can be completed in any order except that FOR 3007H must be taken in the final Summer session and FOR 3008H must be taken in the final Fall session.

Master of Science in Forestry

Overview

Master of Science in Forestry (MScF) students conduct focused research under the supervision of one of our faculty members. Faculty members' research is often interdisciplinary and applied in nature, distilling the utility and impact of discoveries and enabling partnerships with the public, private and non-profit sectors.

Successful candidates come from a variety of backgrounds including biology, botany, ecology, economics, environmental studies, engineering, forestry, agriculture, mathematical and computer science, physical and social sciences, and zoology.

Your program will be developed to reflect your individual strengths and research interests. Research interests of our Faculty Members include (but aren't limited to):

- Forest conservation biology and wildlife ecology
- Forest biosphere science
- Invasive species and threats to forest health
- Environmental sustainability of managed forests
- Fire and ecosystem management
- Sustainable development and economics
- Political ecology and governance of forests
- Social and cultural ecology of forest ecosystems
- Urban forestry
- Forest Biomaterials Science
- Bioenergy

For more information on degree requirements visit <https://sgs.calendar.utoronto.ca/degree/Architecture,-Landscape,-and-Design>

Master of Science in Forestry Degree Requirements

Sample degree chart included below, please note your enrollment may not exactly match the chart below due to curriculum adjustments/ covid19.

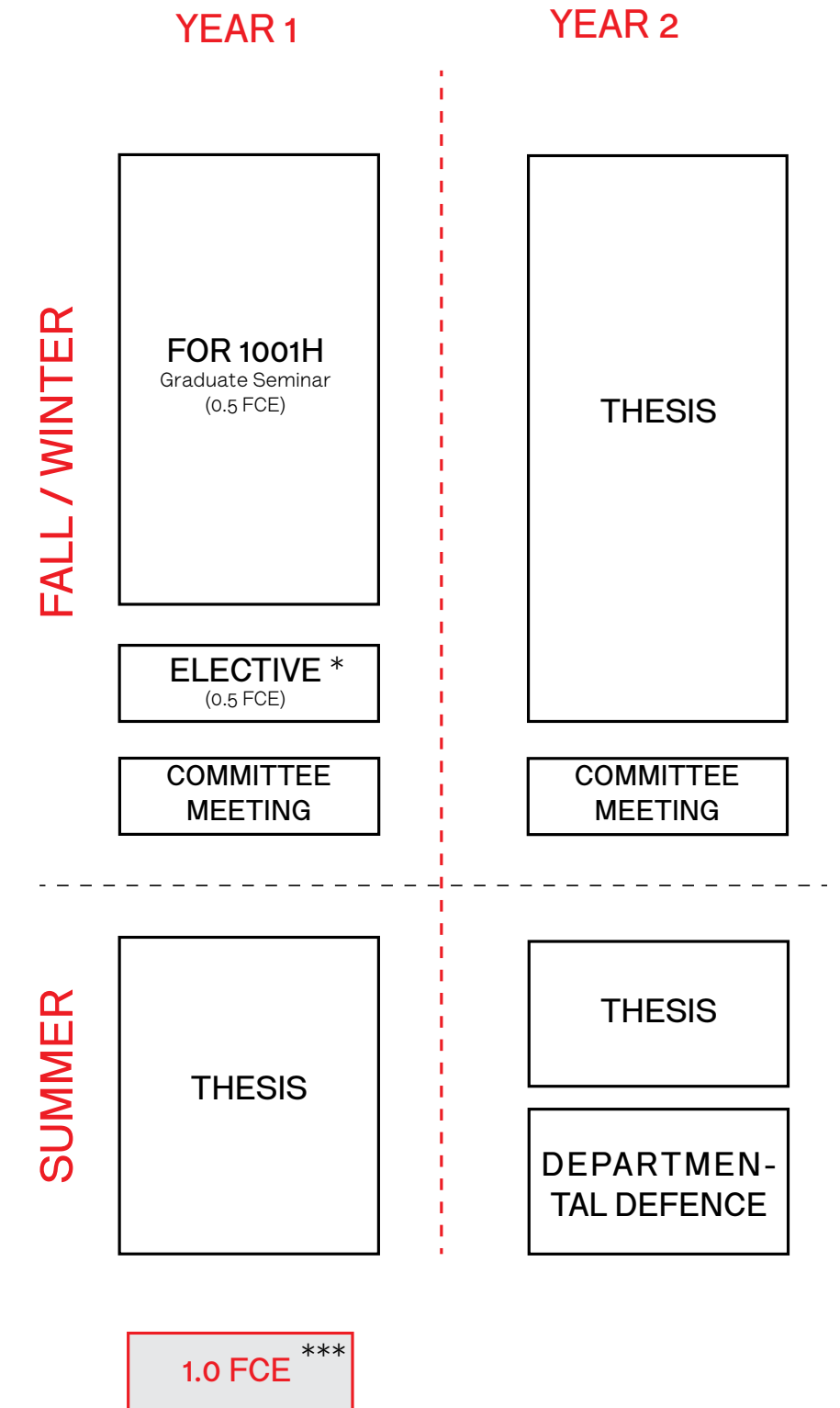

Doctor of Philosophy in Architecture, Landscape, and Design

Overview

The post-professional Doctor of Philosophy in Architecture, Landscape, and Design is a unique, highly rigorous and interdisciplinary program that trains students in multiple specialties and related disciplines to pursue research of the highest academic standard. It includes advanced exploration of the various methodologies of each discipline ranging from theoretical to applied research and produces graduates that can advance the field of conventional academic scholarship while also creating new models of research-based practice that can be implemented in real world settings.

In addition to the core faculty, affiliated faculty with expertise in addressing design problems from multiple disciplinary perspectives in other faculties, schools, and departments across the University of Toronto will be directly involved in the life of the program.

Through a novel curriculum — one that is unlike other Ph.D. programs in architecture schools in Canada or internationally — the Ph.D. program at Daniels requires students in all disciplines to pursue study independently and to share that research with an interdisciplinary cohort at every stage in the curriculum. At the beginning of the curriculum, coursework — including a colloquium and a methods course in the first year, and a practicum and dissertation preparation course in the second — encourages students to work across disciplines in order to familiarize themselves with the broad fields of knowledge necessary to address contemporary scholarly, political, economic, and policy problems. Graduates will be grounded in a research informed practice that will transcend current disciplinary boundaries and position them to engage and lead the emerging, broader discussion, outside and between the specific design disciplines.

Students in the Ph.D. program will have opportunities to work with a wide range of institutions within and beyond the University of Toronto: the Jackman Humanities Institute, the Global Cities Institute, the Munk School of Global Affairs, the Art Museum at the University of Toronto, the Canadian Centre for Architecture, the Royal Ontario Museum, the Art Gallery of Ontario, and the rich array of universities in and near Toronto.

The Ph.D. is intended for students with aspirations in academic research and teaching, research in government and industry, and research within design firms.

For more information on degree requirements visit <https://sgs.calendar.utoronto.ca/degree/Architecture,-Landscape,-and-Design>

Doctor of Philosophy in Architecture, Landscape, and Design Degree Requirements

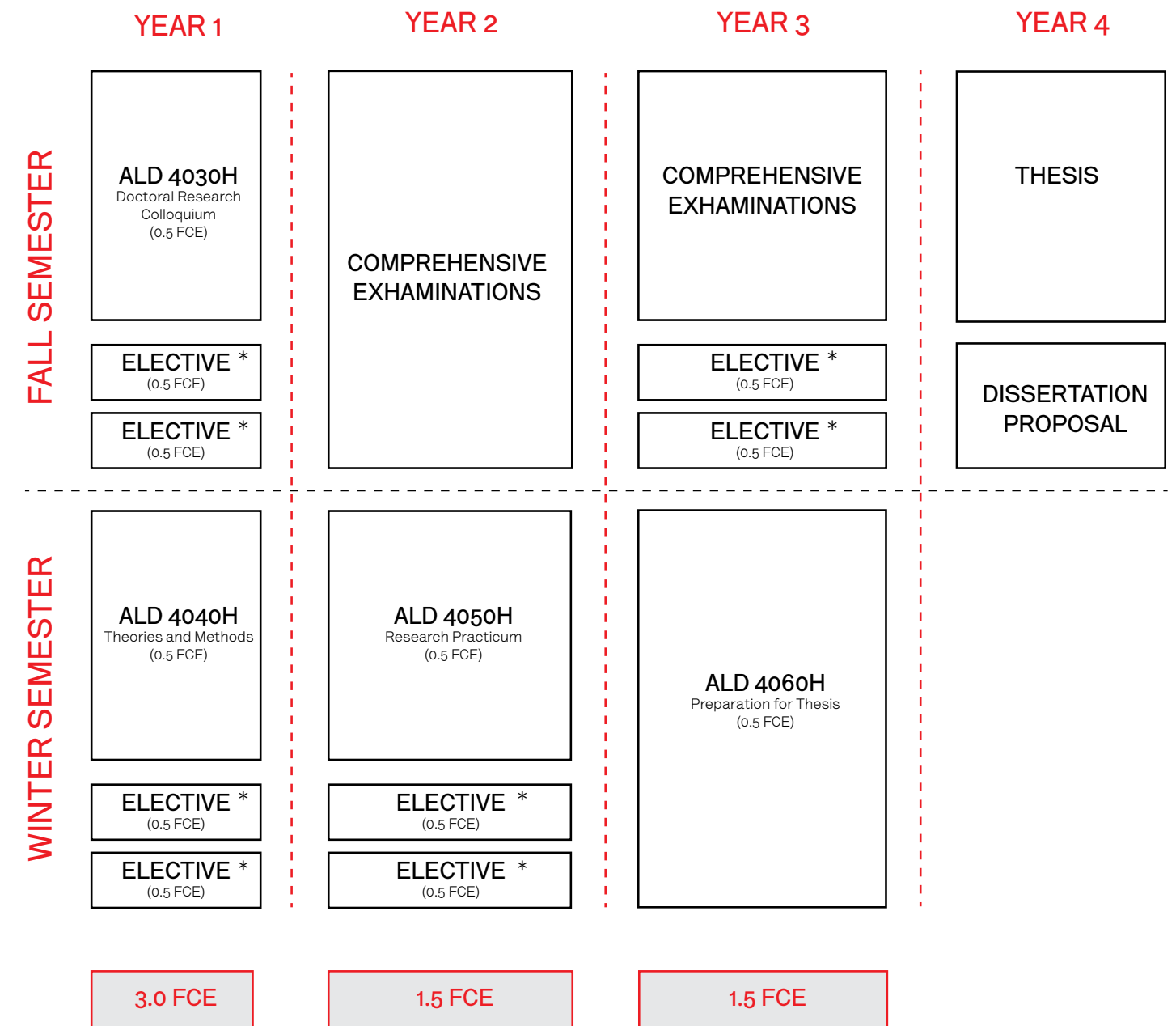

Doctor of Philosophy in Forestry

Overview

Doctor of Philosophy (PhD) students conduct focused research under the supervision of one of our faculty members. Faculty members' research is often interdisciplinary and applied in nature, distilling the utility and impact of discoveries and enabling partnerships with the public, private and non-profit sectors.

Successful candidates come from a variety of backgrounds including biology, botany, ecology, economics, environmental studies, engineering, forestry, agriculture, mathematical and computer science, physical and social sciences, and zoology.

Your program will be developed to reflect your individual strengths and research interests. Research interests of our Faculty Members include (but aren't limited to):

- Forest conservation biology and wildlife ecology
- Forest biosphere science
- Invasive species and threats to forest health
- Environmental sustainability of managed forests
- Fire and ecosystem management
- Sustainable development and economics
- Political ecology and governance of forests
- Social and cultural ecology of forest ecosystems
- Urban forestry
- Forest Biomaterials Science
- Bioenergy

For more information on degree requirements visit <https://sgs.calendar.utoronto.ca/degree/Architecture,-Landscape,-and-Design>

Notes

** Annual Committee meetings are required.

*** Minimal course requirements for this degree are 2.0 full-course equivalent (FCE). Depending on the student's background, additional or alternative coursework may be required.

**** 4 year program length for:
MScF students that transferred by the end of Year 1 to the PhD program.
Bachelor's degree students who were admitted to the PhD program via direct entry.

Doctor of Philosophy in Forestry Degree Requirements

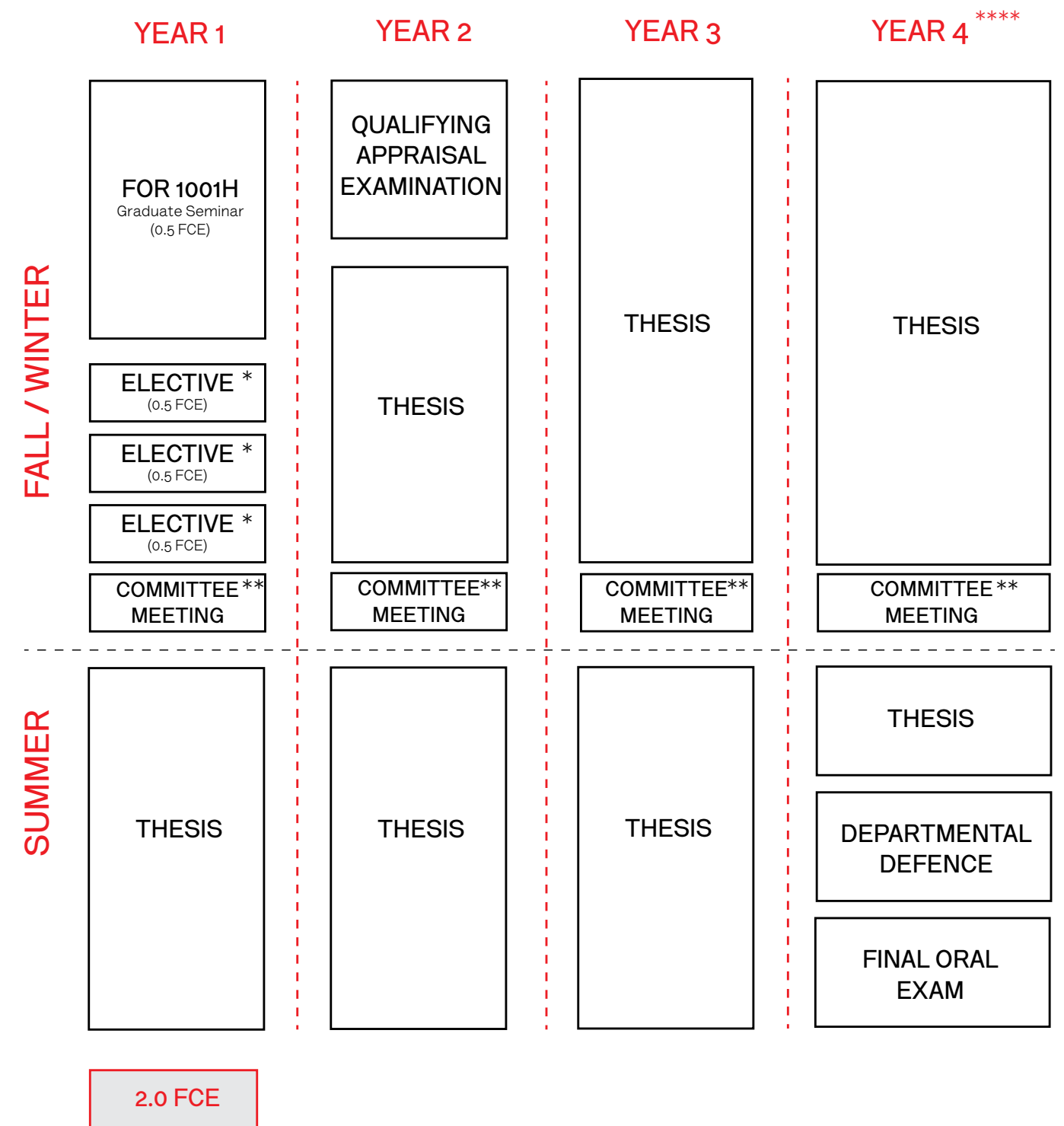

Collaborative Programs and Research Centers

Knowledge Media Design

Students with strong interests and skills in the emerging cross-disciplinary field of Knowledge Media Design may apply for the Collaborative Program in Knowledge Media Design (KMD). As part of the KMDI, the program provides a specialization for graduate students from a variety of academic backgrounds to engage in the design, prototyping, evaluation, and use of media intended to support and enhance the ability of individuals and groups to think, communicate, learn, and create knowledge.

Master's students must successfully complete KMD 1001H, KMD 1002H, and 0.5 full-course equivalent (FCE) from the KMD 2001-2004 series or a list of recognized affiliate courses. They also must submit a portfolio that includes completed student research in Knowledge Media Design. Please visit <http://kmdi.utoronto.ca/> and <http://kmdi.utoronto.ca/program/courses/> for more information.

For more information about applying for the KMD Collaborative Program, go to <http://kmdi.utoronto.ca/program/applying/>

Sexual Diversity Studies

The Mark S. Bonham Centre hosts a collaborative graduate program in Sexual Diversity Studies at the M.A. and Ph.D. levels for faculty and students interested in questions about how we understand sexual diversity and sexual practices.

Among these questions are how we frame and categorize sexual differences, why we fear some and celebrate others, how medical, religious, and political authorities respond to them. What is the nature of sexual identity and orientation? How and why is sexuality labeled as lesbian, heterosexual, perverse, normal, gay, or queer? How do cultures at different times and places divide the sexual from the non-sexual?

For more information, visit <http://www.uc.utoronto.ca/sexualdiversity> or email sexual.diversity@utoronto.ca

Centre for Landscape Research

The Centre for Landscape Research (CLR) provides a support structure and a culture of research aimed at enhancing the knowledge base of the profession of landscape architecture at the University of Toronto. Also, it seeks to complement research infrastructure to the benefit of the MLA, MUD and MArch Programs. The Centre for Landscape Research (CLR) provides a support structure and a culture of research for faculty and students who have research interests overlapping with the knowledge base of landscape architecture. CLR began in the early 1980's in conjunction with graphics and user interface research into computer aided design (CAD) and geographic information systems

(GIS). CLR was formally constituted as a Centre in the Faculty in 1989 with Professor Fife as the first Director. The centre is currently co-directed by professors Danahy and Wright.

The CLR is committed to multidisciplinary research and welcomes participants from any discipline. CLR is closely associated with the Knowledge Media Design Institute (KMDI) and the Cities Centre at the University of Toronto. Most recently, the CLR has been collaborating with the National Centre of Excellence (NCE) in geomatics called GEOIDE through projects in visualizing climate change mitigation with CALP at UBC and Planning at U of Waterloo. A second NCE project lead by the Cities Centre is examining the integration of GIS based urban models and transportation models.

Throughout its history CLR has extended its facilities and activities in a transdisciplinary way to KMDI, Cities Centre, Architecture, Planning, and Urban Design. The Centre has no base budget and does not do teaching; instead, it coordinates infrastructure and funding contributed by faculty to enhance teaching that fosters graduate research with an interest in landscape. In addition to its funded labs, CLR has supported and fostered a variety of individual research activities on specific research topics developed by individual faculty in landscape architecture over many years.

The CLR has two research laboratories (Immersive visualization and the Green Roof Innovation Testing – GRIT- lab) in which several faculty collaborate. The digital media project has been running since the early 1980's and tackles unique projects and research questions that look into ways of adapting the disciplinary language and methods of landscape architecture through spatial computing and design-planning practice. The laboratory has specialized in projective urban modeling and visualization. The immersive visualization room established in partnership with Parallel World Labs (a Toronto based company established by alumni of CLR) is used as a prototype urban design decision theatre.

The second research facility in CLR is the Green Roof Innovation Testing (GRIT) lab. The GRIT is dedicated to the study of Green Roofs, Green Facades and Solar Technologies and is led by Professor Liat Margolis.

Cities Centre

The Cities Centre promotes and undertakes university-based, interdisciplinary research across the spectrum of urban issues. These disciplines include physical infrastructure, social infrastructure, economic development, urban design, governance, finance, health, environment and other related fields. Their goal is to network the diverse strengths of these disciplines within the University to provide a holistic approach to major urban planning, design, development and management policy issues.

Please see the Cities Centre website for more information at: <http://citiescentre.webservices.utoronto.ca/>

Travel Abroad

Safety Abroad

The Safety Abroad Office works with students, staff and faculty to minimize risk by:

- Providing Safety Abroad Workshops
- Monitoring international security situations
- Assisting students with emergencies abroad
- Offering a 24-hour emergency line

Students must register with the Safety Abroad Office (SAO) and participate in a mandatory Safety Abroad Workshop before participating in a University-sponsored program overseas. The Safety Abroad Office provides support services to give students peace of mind while away from home.

Please see: <http://www.studentlife.utoronto.ca/cie/safety-abroad>

Global Architecture

The Global Architecture option offers students in the graduate programs the opportunity to study abroad within a design and research-oriented summer program. Courses are taught by Daniels faculty members, as well as leading architects and faculty from abroad. GA identifies and studies areas in flux, where the relations between local conditions and global modernizing strategies need to be negotiated. In each venue, the program seeks to identify the distinctive features of the architectural and urban culture of the place and how these features are formed and transformed by design, planning, and historical forces. GA programs have been held in Buenos Aires, Havana, Barcelona, the Netherlands, and China.

Global Architecture 2012, 2013 & 2014 - São Paulo

Global Architecture courses in São Paulo, which took place in 2012, 2013, and 2014 was designed, organized, and taught by Alexander Pilis. The programs were undertaken in association with the Escola da Cidade and the Centro Cultural São Paulo. They accepted Brazilian students from various universities in São Paulo to develop site-specific projects in tandem with Canadian students. Escola da Cidade University in São Paulo and John H. Daniels Faculty of Architecture, Landscape, and Design University of Toronto have an agreement in place towards an institutional student exchange program.

The students were immersed in a metropolis with a population of 21 million. The city has no central plan, and a multi-layer urban condition that is in constant change. Student projects addressed the Minhocão, a 3.5 kilometer suspended highway that cuts through the city creating distinct urban and social conditions. The highway has devastated the immediate environment through carbon dioxide and noise pollution, leading to a devaluation of social activity and the abandonment of real estate. The local community recently took over the highway to address and re-think how to solve these problems.

In parallel with the assigned projects focused on the Minhocão, students were given special tours of major modern buildings by Oscar Niemeyer, Lina B Bardi, Vilanova Artigas, Isay Wienfeld and Paulo

Mendes da Rocha. Isay Wienfeld and Pritzker Prize winner Paulo Mendes da Rocha also gave personal tours of their buildings. Students were also introduced to social housing projects developed by the city's urban planners.

A one-week trip to Rio de Janeiro included visits to Affonso Reidy's, Modern Art Museum and his social housing project, Pritzker Prize winner Oscar Niemeyer's Contemporary Art Museum, Olavo Redig de Campos' Institute Moreira Salles and 19th century botanic garden. The guest professor for Rio was Milton Machado, the director of the Federal University of Rio de Janeiro.

In between tours, students explored the city and had the opportunity to learn about the historical remains of the Imperial and Colonial periods in Brazil. Some students also took side trips to other Brazilian cities.

A publication on the 2014 program can be found online.



Important Dates 2020-21

For a full listing of sessional dates, please see our website. <https://www.daniels.utoronto.ca/info/current-students/graduate/sessional-dates>

August 2020

1	Forestry students begin course enrolment on ACORN All other Daniels students may begin enrolling in outside Faculty electives via ACORN
3	Civic Holiday (University Closed)
17-21	WORKSHOP for newly admitted students
24 - Sept 4	ALA4010H, ALA4020H, ARC1021HF and ARC2042HF and URD1021HF - August intensives
25	PhD all years begin course elective course enrolment on ACORN Post Professional MArch and MLA begin elective course enrolment on ACORN MArch year 4 students begin elective course enrolment on ACORN MLA year 3 students begin elective course enrolment on ACORN MUD year 2 students begin elective course enrolment on ACORN MVS year 2 students begin elective course enrolment on ACORN
26	MArch year 3 students begin elective course enrolment on ACORN
27	MArch year 2 students begin elective course enrolment on ACORN MLA year 2 students begin elective course enrolment on ACORN MUD year 1 students begin elective course enrolment on ACORN MVS year 1 students begin elective course enrolment on ACORN
28	Elective enrolment open to ALL Daniels students Deadline to submit Fall independent study proposals. Recommended tuition fee payment deadline for students registering or starting their program in the Fall to ensure payment is received by the registration deadline of September 11, and to avoid cancellation of registration and course enrolment.
31 - Sept 4	LAN1041HF Field Studies 1
31 - Sept 11	Forestry Field Course (FOR1585H)

September

1	LIVE Q & A session for MLA studio ballot LAN3016Y, time TBC LIVE Q & A session for MARC and MUD studio ballot ARC3020Y & URD2013Y, time TBC
3	Deadline to submit all Studio Ballots 11:59 EST (ARC3020Y, LAN3016Y, URD2013Y)
7	Labour Day (University Closed)
8	FOR3001F Biodiversity of Forest Organisms, course begins
TBC	Elective enrolment open to all Daniels Faculty students (Incl Forestry Students)
TBC	Out of Faculty students able to request enrolment in Daniels Faculty electives using the SGS add/drop form

10	Daniels Faculty graduate courses and seminars begin;
10	First day course overload requests accepted.
10 - 17	Field Course: FOR3001 - Biodiversity of Forest Organisms
11	Summer session grades available for viewing by students on ACORN. Registration deadline for students registering or starting their program in the Fall (September to December) session; after this date, a late registration fee will be assessed. Minimum required payment due (unpaid fees from previous session[s] + 100% of current Fall tuition fee charges).
14	Forestry Fall Electives commence this week
20	Final day fall and full-year courses waitlist operational
21	Final date to add full-year and fall session courses FOR1001HY Graduate Seminar commences All other Forestry MFc Fall Core First Year Courses commences this week
30	Payment deadline to avoid service charges on unpaid Fall (September to December) session tuition and non-tuition fees for students registered in the Fall session only, except for those who have successfully registered without payment Summer session grades available for viewing by students on ACORN.

October

12	Thanksgiving Day (University closed)
26	Final date to drop fall session full or half credit courses without academic penalty.
TBC	Application for current third year students to confirm transition to MARC 3 year program or decision to remain in 3.5 year program

November

TBC	PhD all years begin course elective course enrolment on ACORN Post Professional MArch and MLA begin elective course enrolment on ACORN MArch year 4 students begin elective course enrolment on ACORN MLA year 3 students begin elective course enrolment on ACORN MUD year 2 students begin elective course enrolment on ACORN MVS year 2 students begin elective course enrolment on ACORN
TBC	MArch year 3 students begin elective course enrolment on ACORN
TBC	MArch year 2 students begin elective course enrolment on ACORN MLA year 2 students begin elective course enrolment on ACORN MUD year 1 students begin elective course enrolment on ACORN MVS year 1 students begin elective course enrolment on ACORN
TBC	Elective enrolment closed
TBC	Elective enrolment open to all Daniels Faculty students (Incl Forestry Students)
TBC	Out of Faculty students able to request enrolment in Daniels Faculty electives using the SGS add/drop form
30	Payment deadline to avoid service charges on unpaid Winter (January to April) session tuition and non-tuition fees for students registered in

the Fall and Winter sessions, except for those who have successfully registered without payment because they are receiving a full funding package via a research stipend, a major award or scholarship, teaching assistantships, tuition waiver, and/or sponsorships.

December

1	Deadline for current third year students to confirm transition to MARC 3 year program or decision to remain in 3.5 year program Deadline to submit Winter independent study proposals
11 - 22	Final Examination and Studio Reviews period The final examination period runs until December 22, 2020. Please note that all students are expected to make themselves available throughout the examination period, until the final examination schedule has been confirmed. It is possible that final exams/reviews may be scheduled on December 22, 2020.
TBC	Out of Faculty students able to request enrolment in Daniels Faculty electives using the SGS add/drop form First day Daniels Faculty students can overload Winter enrolment.
18	Recommended tuition fee payment deadline for students registering or starting their program in the Winter to ensure payment is received by the registration deadline of January 14, and to avoid cancellation of registration and course enrolment
23 - Jan 1	University closed for winter break from Wednesday, December 23 to Friday, January 1 inclusive

January 2021

4	University Re-opens All Daniels Faculty graduate courses and seminars begin
13	Fall session grades available for viewing by students on ACORN
17	Final day winter courses waitlist operational
18	Final date to add winter session courses Registration deadline for students registering or starting their program in the Winter (January to April) session; after this date, a late registration fee will be assessed. Minimum required payment due (unpaid fees from previous session[s] + 100% of current Winter session tuition fee charges)
22	Final date for all students to request that their degrees be conferred in absentia in March
31	Payment deadline to avoid service charges on unpaid Winter (January to April) session tuition and non-tuition fees for students registered in the Winter session only, except for those who have successfully registered without payment because they are receiving a full funding package via a research stipend, a major award or scholarship, teaching assistantships, tuition waiver, and/or sponsorships. Monthly service charges will begin accruing on February 15.

February

15	Family Day (University closed)
15-19	Reading Week (no Daniels Faculty classes)
22	Final date to drop full-year and winter session courses without academic penalty

March

April

2	Good Friday (University Closed) Final Examination Period
TBA	The final examination period runs until April 30, 2021. Please note that all students are expected to make themselves available throughout the examination period, until the final examination schedule has been confirmed. It is possible that final exams/reviews may be scheduled on April 30, 2021.
TBA	LAN1043HS Field Studies 2



Select UofT Services

Academic Success Centre

Koffler Student Services Centre - 214 College Street
Tel: 416-978-7970 / mail.asc@utoronto.ca www.asc.utoronto.ca

The Centre offers lectures, workshops, and group or individual counselling on topics such as time management, procrastination, and taking lecture notes to help you develop the skills, strategies, and competencies that you need to succeed.

Accessibility Services

455 Spadina Avenue, Fourth Floor, Suite 400
Tel: 416-978-8060 / accessibility.services@utoronto.ca
www.accessibility.utoronto.ca

Accessibility Services supports students through academic accommodations to achieve academic and co-curricular success. They provide confidential services such as test and exam accommodations support in determining and regulating effective accommodations, and expertise in learning strategies and adaptive technology.

UofT Bookstore

Koffler Student Services Centre - 214 College Street Tel: 416-640-7900 /
info@uoftbookstore.com www.uoftbookstore.com

The Bookstore is the place to buy supplies such as textbooks, paper, pencils, and, software, as well as University of Toronto clothing such as sweatshirts, t-shirts, and jackets.

University of Toronto Libraries

<http://onereach.library.utoronto.ca>

There are many libraries on campus; this website provides you with information about each library.

University of Toronto Writing

www.writing.utoronto.ca/

This website functions as a resource centre for students wishing to improve their writing skills, including information about writing courses, FAQs, books and other resources, and advice

Safety and Security

The University of Toronto and the Daniels Faculty work to provide a safe and secure environment for all students and we encourage you to be especially conscious of your personal security. We stress the importance of not allowing strangers into residences, of locking doors, of never leaving personal belongings unattended, and of not walking alone in unlit areas.

Access to the Daniels buildings on campus is by FOB key only after regular business hours. For security, do not let anyone into the Daniels buildings who does not have their own FOB key. <http://safety.utoronto.ca/>

UT Alert

<http://alert.utoronto.ca/>

The UT Alert system is the most reliable source of information regarding any campus closures related to weather or other safety concerns. To receive text or phone alerts go to alert.utoronto.ca and register using your UTORid and password.

TravelSafer

Tel: (416) 978-SAFE (7233)

<http://campuspolice.utoronto.ca/travelsafer-2/>

TravelSafer is a free University of Toronto service that provides a reliable, safer alternative to walking alone at night. The program runs seven days a week, 365 days a year, from dusk until dawn. To request accompaniment by patrollers, contact (416) 978-SAFE (7233). Patrollers are friendly individuals who are carefully screened by a hiring committee before being employed. They can be identified by photo badges and distinctive jackets that they wear while on duty.

Health and Wellness Services

214 College Street, Second Floor, University of Toronto
Tel: 416-978-8030
www.healthandwellness.utoronto.ca

Wellness refers to your overall physical, emotional, intellectual, spiritual and social condition, not simply the absence of illness. So when you're not feeling your best, the friendly team at the Health and Wellness Centre offers a wide range of services to support you in achieving your personal and academic best. The Health and Wellness team includes family physicians, registered nurses, counsellors, psychiatrists, a dietitian, and support staff. They provide confidential, student-centred health care, including comprehensive medical care, immunization, sexual health care, counselling and referrals. Services are available to all full- and part-time students who possess a valid TCard and have health insurance coverage.

Multi-Faith Centre

569 Spadina Ave., University of Toronto Tel: 416-946-3120
<https://www.studentlife.utoronto.ca/mf>

While the University of Toronto is a secular institution we recognize the important role that faith and worship plays in the lives of many people. Whether you are looking for support around grief, wanting to join a regular meditation group, wanting to explore interfaith dialogue, visit one of the many chaplains available by appointment, or find a group to worship with, the Multi-Faith Centre provides a myriad of support and resources.

Centre for International Experience

33 St. George Street
Tel: 416-978-2564 / cie.information@utoronto.ca; student.exchange@utoronto.ca
<http://cie.utoronto.ca/>

The CIE promotes and supports international education and offers services, programs, and facilities for international students, students with international and/or intercultural interests, and students looking for education/work abroad.



Career Centre

Koffler Student Services Centre - 214 College Street, Main Floor
Tel: 416-978-8000 / careercentre@mail.careers.utoronto.ca
www.careers.utoronto.ca

The Career Centre offers employment listings, including work-study postings, volunteer listings, career development workshops and seminars.

Fitness and Recreation

<http://athletics.utoronto.ca/>
<http://harthouse.ca/fitness/>

We recognize that academic success can be related to participation in physical activity. Whether you are interested in dropping in for a Pilates class, lifting weights on your own, swimming lengths, or taking a regularly scheduled class, your valid TCard gives you access to fitness facilities on campus including the Hart House gym, the Goldring Centre, and the Athletic Centre.

Housing Services

Koffler Student Services Centre - 214 College Street, Second Floor, Room 203
Tel: 416-978-8045 / housing.services@utoronto.ca
www.housing.utoronto.ca/

Housing Services offers information, resources, and supports to help students meet their housing needs.

Student Life

www.studentlife.utoronto.ca/

Ulife

www.ulife.utoronto.ca/

What are you doing after class? This website lists numerous clubs, activities, and community events in which you may wish to get involved.

University of Toronto Students' Union

<http://utsu.ca/>

All undergraduate and professional faculty students on the St. George campus belong to this student union.

